

**OILGEAR TYPE “PVWJ” PUMPS -  
PVWJ-011/-014/-022/-025/-034/-046/-064/  
-076/-098/-130  
SERVICE INSTRUCTIONS**

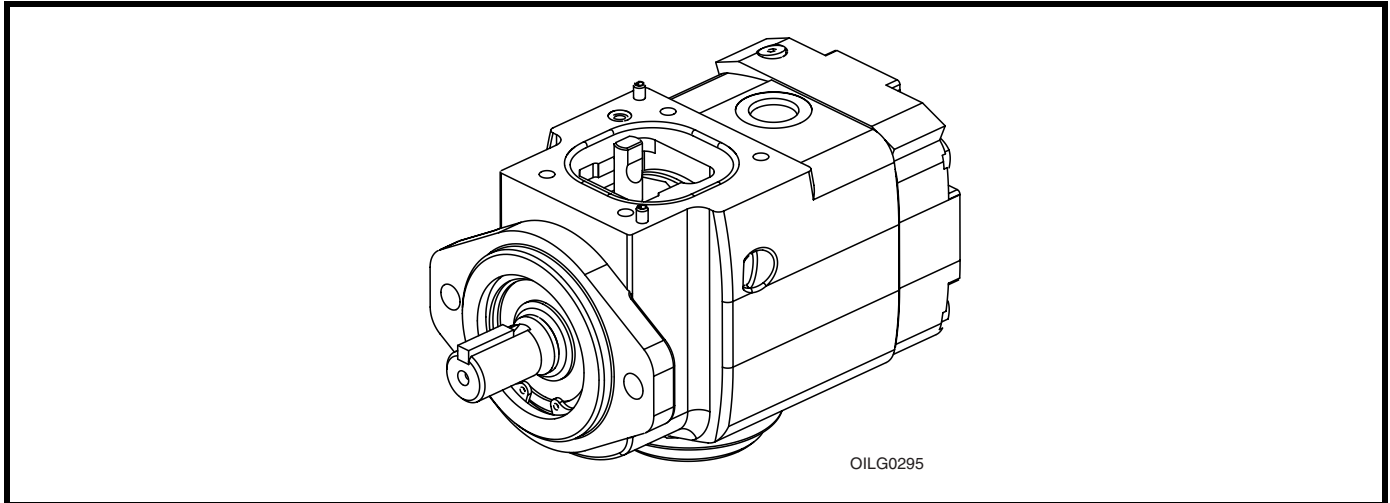

Figure 1. Typical Oilgear “PVWJ” Open Loop Pump

**PURPOSE OF INSTRUCTIONS**

These instructions will simplify the installation, operation, maintenance and troubleshooting of Oilgear type “PVWJ” pumps.

Become familiar with the construction, principle of operation and characteristics of your pump to help you attain satisfactory performance, reduce shut-down and increase the pump's service life. Some pumps have been modified from those described in this bulletin and other changes may be made without notice.

**REFERENCE MATERIAL**

|   |                 |
|---|-----------------|
| Fluid Recommendations .....   | Bulletin 90000  |
| Contamination Evaluation Guide.....                                     | Bulletin 90004  |
| Filtration Recommendations .....  | Bulletin 90007  |
| Piping Information .....  | Bulletin 90011  |
| Proper Installation of Vertical Pumps .....                             | Bulletin 90014  |
| Alternate Remote Compensating of Single/Multiple Load Sense Pumps ..... | DS-47974-A      |
| PVWJ Open Loop Pumps, Application Guidelines.....                       | Bulletin 847085 |
| PVWJ Open Loop Pumps, Sales .....                                       | Bulletin 47085  |

(continued)

## **PVWJ BASIC PUMP INSTALLATIONS**

|  |          |
|--|----------|
| PVWJ A Frame (PVWJ-011/-014/-022) w/ Rear Ports.....                         | DS-47480 |
| PVWJ A Frame (PVWJ-011/-014/-022) w/ Side Ports .....                        | DS-47481 |
| PVWJ A Frame (PVWJ-011/-014/-022) w/ Side Ports & Thru Shaft.....            | DS-47482 |
| PVWJ B Frame (PVWJ-025/-034/-046) w/ Rear Ports.....                         | DS-47483 |
| PVWJ B Frame (PVWJ-025/-034/-046) w/ Side Ports .....                        | DS-47484 |
| PVWJ B Frame (PVWJ-025/-034/-046) w/ Side Ports & Thru Shaft.....            | DS-47485 |
| PVWJ C Frame (PVWJ-064) w/ Rear Ports.....                                   | DS-47486 |
| PVWJ C Frame (PVWJ-064) w/ Side Ports & w/ or w/o Thru Shaft.....            | DS-47487 |
| PVWJ C Frame (PVWJ-076/-098/-130) w/ Rear Ports .....                        | DS-47488 |
| PVWJ C Frame (PVWJ-076/-098/-130) w/ Side Ports & w/ or w/o Thru Shaft ..... | DS-47489 |

## **PVWJ PUMP CONTROL INSTRUCTIONS**

|   |                 |
|---|-----------------|
| “P-1NN” and “P-LNN” Pressure Compensator for PVWJ-011/-014/-022 .....                           | Bulletin 947633 |
| “P-1NN” and “P-LNN” Pressure Compensator for PVWJ-025/-034/-046 .....                           | Bulletin 947634 |
| “P-1NN” and “P-LNN” Pressure Compensator for PVWJ-064/-076/-098/-130..                          | Bulletin 947635 |
| “P-1NN/F” and “P-LNN/F” Pressure Compensator w/ Load Sense for<br>PVWJ-011/-014/-022.....       | Bulletin 947636 |
| “P-1NN/F” and “P-LNN/F” Pressure Compensator w/ Load Sense for<br>PVWJ-025/-034/-046.....       | Bulletin 947637 |
| “P-1NN/F” and “P-LNN/F” Pressure Compensator w/ Load Sense for<br>PVWJ-064/-076/-098/-130 ..... | Bulletin 947638 |
| “P-CNN” and “P-KNN” Soft Start Pressure Compensator for<br>PVWJ-011/-014/-022.....              | Bulletin 947639 |
| “P-CNN” and “P-KNN” Soft Start Pressure Compensator for<br>PVWJ-025/-034/-046.....              | Bulletin 947640 |
| “P-CNN” and “P-KNN” Soft Start Pressure Compensator for<br>PVWJ-064/-076/-098/-130 .....        | Bulletin 947641 |
| Dual Pump Adapters for PVWJ Pumps (all sizes) .....   | DS-47490        |
| Alternate Remote Compensating of Single or Multiple Load Sense Pump .....                       | DS-47974-A      |

## **PVWJ PUMP CONTROL INSTALLATIONS**

|  |          |
|--|----------|
| “P-1NN” and “P-LNN” Pressure Compensator for PVWJ-011/-014/-022 .....                            | DS-47984 |
| “P-1NN” and “P-LNN” Pressure Compensator for PVWJ-025/-034/-046 .....                            | DS-47985 |
| “P-1NN” and “P-LNN” Pressure Compensator for PVWJ-064/-076/-098/-130.....                        | DS-47986 |
| “P-1NN/F” and “P-LNN/F” Pressure Compensator w/ Load Sense for<br>PVWJ-011/-014/-022.....        | DS-47987 |
| “P-1NN/F” and “P-LNN/F” Pressure Compensator w/ Load Sense for<br>PVWJ-025/-034/-046.....        | DS-47988 |
| “P-1NN/F” and “P-LNN/F” Pressure Compensator w/ Load Sense for<br>PVWJ-064/-076/-098/-130 .....  | DS-47989 |
| “P-CNN” and “P-KNN” Soft Start Pressure Compensator for<br>PVWJ-011/-014/-022.....               | DS-47990 |
| “P-CNN” and “P-KNN” Soft Start Pressure Compensator for<br>PVWJ-025/-034/-046.....               | DS-47991 |
| “P-CNN” and “P-KNN” Soft Start Pressure Compensator for<br>PVWJ-064/-076/-098/-130 .....         | DS-47992 |
| PVWJ Remote Circuit Drawing “P-1NN/F” or “P-LNN/F” Single Pressure<br>w/ Load Sense Control..... | DS-47491 |

Read and understand this entire instruction sheet before repairing, or adjusting your Oilgear product.

Those who use and maintain this equipment must be thoroughly trained and familiar with the product. If incorrectly used or maintained, this product and its equipment can cause severe injury.

## SAFETY SYMBOLS

The following signal words are used in this instruction sheet to identify areas of concern where your safety may be involved. Carefully read the text and observe any instructions provided to ensure your safety.

### **DANGER**

**THIS SIGNAL WORD INDICATES AN IMMEDIATELY HAZARDOUS SITUATION WHICH, IF NOT AVOIDED, WILL RESULT IN DEATH OR SERIOUS INJURY.**

### **WARNING**

This signal word indicates a potentially hazardous situation which, if not avoided, could result in death or serious injury.

### **CAUTION**

This signal word indicates that a potentially hazardous situation exists which, if not avoided, may result in damage to equipment or minor personal injury.

#### **NOTE**

*While not directly relevant to the topic being discussed, the NOTE is used to emphasize information provided, or provide additional information which may be of benefit.*

### **WARNING**

This service information is designed for the maintenance of your Oilgear product. It contains the information on the correct procedures determined by Oilgear for the safe manner of servicing. Always keep this instruction sheet in a location where it is readily available for the persons who use and maintain the product. Additional copies of this instruction sheet are available through the Oilgear Company. Contact us at 414-327-1700 or visit our website: [www.oilgear.com](http://www.oilgear.com). Please contact us if you have any questions regarding the information in this instruction bulletin.

#### **NOTE**

*The cleanliness of working on this pump or the hydraulic system is extremely important to the safety and reliability of the pump and the system. Always make sure the fittings are clean on the outside before removing them from their connections, are capped and plugged when removed and placed in a clean rag or container until they are reinstalled.*

### **WARNING**

Some service operations may require special tools or equipment. If you require information on these items, please contact Oilgear before attempting these repairs and service operations.

### **WARNING**

Read, understand, and follow the safety guidelines, dangers, and warnings contained in this instruction sheet to promote reliable operation and prevent serious personal injury.

### **WARNING**

DO NOT attempt to service this machinery in an environment where safety regulations are not established and in place.

### **WARNING**

DO NOT operate the hydraulic system if a leak is present. Serious injury may result.

### **WARNING**

Hydraulic systems operate under very high-pressure. Hydraulic fluid escaping from a pressurized system can penetrate unprotected body tissue. DO NOT inspect for hydraulic leaks with bare hands or other exposed body parts. As a minimum, wear leather gloves prior to inspecting for leaks and use cardboard or wood. If leaks are present, relieve pressure and allow system to cool prior to servicing. If injured by escaping hydraulic oil, contact a physician immediately. Serious complications may arise if not treated immediately. If you have questions regarding inspecting for hydraulic leaks, please contact Oilgear prior to servicing.

### **WARNING**

Hydraulic hoses and tubing must be inspected on a daily basis for leaks, cuts, abrasions, damage and improper clearance along any mounting frame for hidden damage before the unit is put into service. Replace damaged hoses or hoses you suspect are damaged before the system is returned to service! Hoses must be replaced every two years. Failure to properly inspect and maintain the system may result in serious injury.

### **WARNING**

Hydraulic systems are hot. **DO NOT TOUCH!** Serious personal injury may result from hot oil. When you have completed working on the hydraulic system, thoroughly clean any spilled oil from the equipment. Do not spill any hydraulic fluids on the ground. Clean any hydraulic fluids from your skin as soon as you have completed maintenance and repairs. Dispose of used oil and system filters as required by law.

### **WARNING**

Use correct hoses, fittings, and adapters with the correct SAE rating when replacing hoses to prevent possible serious injury. Always replace hoses, fittings, and adapters with replacements that have a proper, suitable, working pressure rating. Replacement hoses must be of the correct length and must comply with the hose manufacturer's and Oilgear's installation guidelines and recommendations.

### **WARNING**

Hydraulic hoses have the SAE ratings marked on the hose to assist you in selecting the correct hose. The same manufacturer must supply any replacement hydraulic hoses and fitting assemblies. As an example: Brand "X" hose and brand "Y" fitting will not normally be compatible. No "Twist" is allowed in the hydraulic hoses. "Twist" may result in premature hose failure. This can cause serious injury. Please contact Oilgear for assistance when required.

### **WARNING**

Hydraulic cylinders can be holding a function in a certain position when the pump is OFF. An example of this is a function being held in the lift or partial lift position by the cylinders. If a hydraulic line is removed or the hydraulic circuits or controls are being worked on, gravity may allow the function being held in position to drop. All workers and personnel must remain clear of these areas when working on or operating the hydraulic system. Block and secure all devices and functions which apply before beginning work or operation. Failure to comply with this can result in serious injury or death.

### **WARNING**

Any hydraulic pipe which is replaced must conform to SAE J1065 specifications. If incorrect hydraulic pipe is installed, the hydraulic system may fail, causing serious injury. Damaged or leaking fittings, pipes or hoses must be replaced before the system is returned to service.

### **WARNING**

**DO NOT** heat hydraulic pipe. The carbon content of this steel tube is such that if heated for bending, and either water or air quenched, the pipe may lose its ductility and thereby be subject to failure under high-pressure conditions. Serious injury can result. Damaged or leaking pipes must be replaced before the system is returned to service. Please contact Oilgear if you require assistance or have questions.

### **WARNING**

All hydraulic pressure must be relieved from the hydraulic system prior to removing any components from the system. To relieve the hydraulic pressure from the hydraulic system, turn off the motor and operate the control panel with the key in the ON position. Failure to comply can result in serious injury. If you have any questions concerning relieving the hydraulic pressure from the system, please contact Oilgear.

**⚠ WARNING**

Hydraulic components can be heavy. Use caution while lifting these components. Serious personal injury can be avoided with proper handling of the components.

**⚠ WARNING**

Please contact Oilgear if you require assistance, when performing hydraulic test procedures, use the proper hydraulic gauges. Installing an incorrect test gauge could result in serious injury if the gauge fails. Use properly rated hydraulic hoses to allow the test gauge to be read away from moving parts and functions.

**⚠ WARNING**

Increasing hydraulic pressure beyond the recommendations may result in serious damage to the pump and system or serious personal injury and may void the Oilgear Warranty. If you have questions concerning hydraulic pressures or testing procedures, please contact Oilgear before attempting the test procedures or making adjustments.

**⚠ WARNING**

An Oilgear pump or pump control must not be modified in any way without authorization from Oilgear. Modifications may not comply with safety standards, including ANSI safety standards, and may result in serious personal injury. Please contact Oilgear if you require assistance.

**⚠ WARNING**

**DO NOT** enter under hydraulic supported equipment unless they are fully supported or blocked. Failure to follow this procedure can result in serious injury or death.

**⚠ WARNING**

Any Oilgear pump safety decals must be replaced anytime they are damaged, missing, or cannot be read clearly. Failure to have proper decals in place can result in serious injury or death. (If you require safety decals, please contact Oilgear for replacement safety decals, at no charge.)

**⚠ WARNING**

Be sure everyone is clear of the area around the hydraulic system before operating after servicing. Remain attentive at all times when operating to check your work until you are completely sure it is safe to return to service. Failure to heed this warning may result in serious personal injury or death.

**⚠ WARNING**

Wear the proper protective clothing when operating, servicing or maintaining the hydraulic system or the Oilgear pump. Wear the correct protective gear, safety glasses, gloves, and safety shoes. Serious injury can result without proper protective gear.

**⚠ WARNING**

Make sure to keep hands and feet and other parts of your body clear of revolving or moving parts. Failure to comply can cause serious injury.

**⚠ WARNING**

**DO NOT** wear watches, rings, or jewelry while working with electrical and mechanical equipment. These items can be hazardous and can cause serious and painful injuries if they come into contact with electrical wires, moving parts, or hydraulic equipment.

### PREPARATION AND INSTALLATION

#### MOUNTING

Pump Without Reservoir - The pump can be mounted in any position. But, the recommended mounting position is with the drive shaft on a horizontal plane and the case drain port 1 on the top side. Secure the pump to a rigid mounting surface. Refer to the referenced Oilgear Piping Information Bulletin 90011.

Pump With Reservoir - These pumps are usually fully piped and equipped. It may be necessary to connect to a super-charge circuit when used. Mount reservoir on level foundation with the reservoir bottom at least 6 inches (152 mm) above floor level to facilitate fluid changes.

#### PIPING AND FITTINGS

Refer to the referenced Oilgear Piping Information Bulletin 90011 and individual circuit diagram before connecting the pump to the system. Inlet velocity must not exceed 5 fps (1,5 mps). Inlet should be unrestricted and have a minimum of fittings.

#### NOTE

*DO NOT use an inlet strainer.*

Arrange line from “case drain” so the case remains full of fluid (non-siphoning). Case pressure must be less than 25 psi (1,7 bar). For higher case pressures and the special shaft seals required, contact our Customer Service. Each drain line must be a separate line, unrestricted, full sized and connected directly to the reservoir below the lowest fluid level. Make provisions for opening this line without draining (siphoning) reservoir.

#### WARNING

Running the pump in NEUTRAL position (zero delivery) for extended periods without a supercharge circuit can damage the pump. The system and pump must be protected against overloads by separate high-pressure relief valves. Install bleed valve(s) at the highest point(s) in system.

#### POWER

Power is required in proportion to volume and pressure used. Motor size recommendations for specific applications can be obtained from The Oilgear Company. Standard low starting torque motors are suitable for most applications.

#### CAUTION

**DO NOT start or stop unit under load unless system is approved by Oilgear. It may be necessary to provide delivery bypass in some circuits.**

#### DRIVE

Verify rotation direction plate on the pump's housing. Clockwise pumps must be driven clockwise and counterclockwise pumps must be driven counterclockwise. Use direct drive coupling. Size and install coupling per manufacturer's instructions.

#### CAUTION

**DO NOT drive the coupling onto the pump drive shaft. If it is too tight, it may be necessary to heat coupling for installation. Refer to manufacturer's instructions.**

Misalignment of pump shaft to driver's shaft should not exceed 0.005 inches (0,13 mm) Total Indicator Readout (TIR) in any plane.



## FILTRATION

Keep the fluid clean at all times to ensure long life from your hydraulic system. Refer to the referenced Oilgear Filtration Recommendations bulletin 90007 and Oilgear Contamination Evaluation Guide Bulletin 90004. Oilgear recommends use of a filter in the pressure or return line. Replace filter element(s) when the filter condition indicator reaches change area at normal fluid temperature. Drain and thoroughly clean filter case. Use replacement element(s) of same beta 10 ratio (normally a ratio of 4 with hydraulic oils).

## FLUID COOLING

When the pump is operated continuously at the rated pressure or frequently at peak load, auxiliary cooling of the fluid may be necessary. Fluid temperature should not exceed limits specified in the referenced Oilgear Fluid Recommendations Bulletin 90000.

## AIR BREATHER

On most installations, an air breather is mounted on top of fluid reservoir. It is important for the breather to be the adequate size to allow air flow in and out of reservoir as fluid level changes. Keep the breather case filled to the “fluid level” mark. About once every six months, remove cover, wash screen in solvent and allow screen to dry, clean and refill case to level mark and install screen. Refer to the manufacturer's recommendations.

## FLUID, FILLING AND STARTING RECOMMENDATIONS

Refer to instruction plate on the unit, reservoir, machine and/or reference, fluid recommendations bulletin. Fire resistant fluids and phosphate ester fluids can be used in accordance with fluid manufacturer's recommendations.

1. Pump all fluid into reservoir through a clean (beta 10 ratio of 4 or more) filter. Fill reservoir to, but not above, “high level” mark on the sight gauge.
2. **Remove case drain line and fill pump case with hydraulic fluid.**
3. Turn drive shaft a few times by hand with a spanner wrench to make sure parts rotate.

| Unit                | Approximate torque to turn drive shaft |
|---------------------|--|
| -011/-014/-022      | 1.7-2.1 ft·lbs<br>(2,3-2,8 N·m)        |
| -025/-034/-046      | 2.9-3.3 ft·lbs<br>(4,0-4,5 N·m)        |
| -064/-076/-098/-130 | 7.9-8.3 ft·lbs<br>(18,8-11,3 N·m)      |

**Table 1. Torque to Turn Shaft**

With pump under “no load” or with pump control at NEUTRAL:

4. Turn drive unit ON and OFF several times before allowing pump to reach full speed. The system can usually be filled by running the pump and operating the control.
5. The fluid level in the reservoir should decrease. Stop the pump. **DO NOT** allow the fluid level to go beyond the “low level.” If the level reaches the “low level” mark, add fluid and repeat step.

### NOTE

*With differential (cylinder) systems, the fluid must not be above “high level” when the ram is retracted or below “low level” when extended. Bleed air from the system by loosening connections or opening petcocks at the highest point in the system. Close connections or petcocks tightly when solid stream of fluid appears.*

## SPECIFICATIONS

**NOTE**

Refer to reference material, pump control material and individual application circuit for exceptions.

| FRAME | UNIT | THEORETICAL MAXIMUM DISPLACEMENT |        | RATED CONTINUOUS PRESSURE |       | MAXIMUM PRESSURE |       | FLOW RATE at 1800 rpm, rated continuous pressure and 14.7 psia (1.0 bar) inlet condition |       | MAXIMUM INLET PRESSURE*<br>psia (bar) |           |             | MAXIMUM SPEED** | POWER INPUT at rated continuous pressure & 1800 rpm |      |
|-------|------|----------------------------------|--------|---------------------------|-------|------------------|-------|--|-------|---------------------------------------|-----------|-------------|-----------------|---|------|
|       |      | in <sup>3</sup> /rev             | ml/rev | psi                       | bar   | psi              | bar   | gpm  | l/mi  | 1200 rpm                              | 1500 rpm  | 1800 rpm    | rpm             | hp  | kw   |
| A     | 011  | 0.66                             | 10,8   | 5000                      | 344,8 | 5800             | 400,0 | 4.2  | 15,9  | 5.4 (.37)                             | 5.7 (.39) | 6.1 (.42)   | 3000            | 16.3  | 12,2 |
|       | 014  | 0.86                             | 14,1   | 4000                      | 275,9 | 4500             | 310,3 | 5.9  | 22,4  | 5.5 (.38)                             | 5.9 (.41) | 6.4 (.44)   | 3000            | 17.7  | 13,2 |
|       | 022  | 1.35                             | 22,1   | 3000                      | 206,9 | 3500             | 241,4 | 9.5  | 36,0  | 5.5 (.38)                             | 6.0 (.41) | 7.0 (.48)   | 3000            | 20.2  | 15,1 |
| B     | 025  | 1.55                             | 25,4   | 5000                      | 344,8 | 5800             | 400,0 | 10.9   | 41,3  | 7.0 (.48)                             | 7.3 (.50) | 8.2 (.57)   | 3000            | 36.5  | 27,2 |
|       | 034  | 2.06                             | 33,8   | 3500                      | 241,4 | 4000             | 275,9 | 14.7   | 55,7  | 7.0 (.48)                             | 7.6 (.52) | 8.4 (.58)   | 3000            | 35.5  | 26,5 |
|       | 046  | 2.83                             | 46,4   | 2500                      | 172,4 | 3000             | 206,9 | 20.6   | 78,1  | 7.2 (.50)                             | 7.9 (.54) | 9.0 (.62)   | 2400            | 35.0  | 26,1 |
| C     | 064  | 3.88                             | 63,6   | 5000                      | 344,8 | 5800             | 400,0 | 27.4   | 103,8 | 7.6 (.59)                             | 8.5 (.59) | 9.5 (.66)   | 2400            | 95.1  | 70,9 |
|       | 076  | 4.67                             | 76,5   | 3500                      | 241,4 | 4000             | 275,9 | 33.7   | 127,7 | 8.0 (.55)                             | 8.6 (.59) | 9.6 (.66)   | 2400            | 80.4  | 60,0 |
|       | 098  | 6.00                             | 98,3   | 2500                      | 172,4 | 3000             | 206,9 | 43.3   | 164,1 | 7.6 (.52)                             | 8.6 (.59) | 9.8 (.68)   | 2400            | 74.1  | 55,3 |
|       | 130  | 7.94                             | 130,2  | 1500                      | 103,4 | 2000             | 137,9 | 58.2   | 220,3 | 8.0 (.55)                             | 9.3 (.64) | 14.5 (1,00) | 1800            | 64.0  | 47,8 |

\* For higher speeds see suction curves.

\*\* Minimum speed 600 rpm

Case pressure should be less than 25 psi (1,7 bar). For higher pressure, consult factory.

Higher speeds available - consult factory.

**Table 2. Nominal Performance Data with 150-300 SSU viscosity fluids.**

| Frame | Unit               | Length |       | Width  |       | Height |       | Weight |      |
|-------|--------------------|--------|-------|--------|-------|--------|-------|--------|------|
|       |                    | inches | mm    | inches | mm    | inches | mm    | lbs.   | kg   |
| A     | 011/-014/-022      | 7.20   | 182,9 | 4.32   | 109,7 | 4.50   | 114,3 | 32     | 14,5 |
| B     | 025/-034/-046      | 8.50   | 215,9 | 5.80   | 147,3 | 6.11   | 155,2 | 68     | 30,9 |
| C     | 064/-076/-098/-130 | 10.44  | 265,2 | 6.76   | 171,7 | 7.18   | 182,4 | 103    | 46,8 |

All dimensions (without controls) are for rear ported units. For dimensions of other configurations, contact your Oilgear Representative or see the appropriate Data Sheet.

**Table 3. Nominal Dimensions and Weights without controls.**

Refer to installation drawings for more detailed dimensions and port configurations.



## TROUBLESHOOTING

| PROBLEM                                 | CAUSES  | REMEDY   |
|---|---|--|
| <b>Unresponsive or Unstable Control</b> | Swashblock (201) bearing surface and/or saddle bearings (204) worn or damaged.                        | Inspect and replace if necessary.                                  |
|   | Control pin (721) and/or hole in swashblock (201) worn significantly.                                 |  |
|   | Saddle bearing locating pins (207) broken.  |  |
|   | Fluid is contaminated.  | Inspect and clean if necessary. See bulletin 90007.                |
|   | Control piston orifice plugged.   | See appropriate control service bulletin.                          |
|   | Contamination trapped between control piston and piston bore is not allowing piston to move smoothly. |  |
|   | Contamination trapped between control spool and spool bore is not allowing spool to move smoothly.    |  |
|   | Faulty remote pressure compensator circuit components.  | Inspect and replace if necessary.                                  |
|   | Hydraulic line between remote pressure compensator components and RP port of control is too long.     | Shorten line length.   |
|   | Insufficient control flow.  | Increase size of control piston orifice (732).                     |
| <b>Insufficient Outlet Volume</b>       | Swashblock (201) not stroking to desired displacement.  | Inspect for obstruction and remove. Replace worn or damaged parts. |
|   | Low input drive speed.  | Refer to appropriate pump performance specifications.              |
|   | Worn or grooved cylinder barrel (101) and/or valve plate (401) mating surfaces.                       | Inspect and replace if necessary.                                  |
|   | Failed drive shaft (301).   |  |
|   | Worn or damaged piston shoes (102) or swashblock (201).   |  |
|   | Worn pistons and/or piston bores.   |  |
|   | Excessive wear or inadequately supported hydrodynamic bearing (202).                                  | Adjust maximum volume stop CCW to increase outlet flow.            |
|   | Maximum volume stop adjusted incorrectly.   |  |
|   | Control piston stuck off stroke.  | See appropriate control service bulletin.                          |
|   | Pressure compensator is set too close to operating pressure.  |  |
| <b>De-strokes at Low Pressure</b>       | Pressure compensator adjustment not set correctly.  | See appropriate control service bulletin.                          |
|   | Control piston orifice (732) plugged.   |  |
|   | Damaged or fractured control spring.  |  |
|   | Severely worn control spool and/or spool bore.  |  |
|   | Damaged or fractured control piston spring.   |  |
|   | Faulty remote pressure compensator circuit components.  |  |
| <b>Excessive Peak Pressure</b>          | Pressure compensator is set too high.   | See appropriate control service bulletin.                          |
|   | Minimum volume stop is set too high.  | Inspect and clean if necessary. See bulletin 90007.                |
|   | Fluid is contaminated.  |  |
|   | Swashblock (201) bearing surface and/or saddle bearings (204) worn or damaged.                        | Inspect and replace if necessary.                                  |
|   | Contamination trapped between control piston and piston bore is not allowing piston to move smoothly. | See appropriate control service bulletin.                          |
|   | Contamination trapped between control spool and spool bore is not allowing spool to move smoothly.    |  |
|   | Hydraulic line between remote pressure compensator components and RP port of control is too long.     | Shorten line length.   |
|   | Faulty remote pressure compensator circuit components.  | Inspect and replace if necessary.                                  |
|   | Restriction in drilled passages between pump outlet port and control spool.                           | Inspect and clean if necessary.                                    |

|                          |  |  |
|--------------------------|--|--|
| <b>Excessive Heating</b> | Operating pump above rated or peak pressure.   | Consult appropriate pump specification for pressure limitations.   |
|                          | Low fluid level in reservoir.  | Verify fluid level is above reservoir suction line.  |
|                          | Insufficient pump inlet pressure.  | Eliminate any obstructions or other pressure drops in pump inlet plumbing. Consult appropriate pump specification for inlet pressure requirements. |
|                          | Air entering pump inlet plumbing.  | Eliminate leaks that would allow air to enter the fluid stream.  |
|                          | Worn pistons (102) or cylinder barrel (101).   | Inspect and replace if necessary.  |
|                          | Worn or damaged cylinder barrel (101) and/or valve plate (401) mating surfaces.          |  |
|                          | Faulty circuit components (continuously blowing relief valve or a high-pressure leak).   | Eliminate leak or replace faulty components.   |
|                          | Insufficient cooling provisions.   | Inspect heat exchanger for obstructions and remove.  |
|                          | Reservoir is too small.  | Consult Bulletin 90050-B, Reservoir Design.  |
| <b>Excessive Noise</b>   | Pump stopped or started incorrectly under load.  | Verify operator procedure.   |
|                          | Low fluid level in reservoir.  | Verify fluid level is above reservoir suction line.  |
|                          | Air entering pump inlet plumbing.  | Eliminate leaks that would allow air to enter the fluid stream.  |
|                          | Broken shoe/piston assembly (102).   | Inspect and replace if necessary.  |
|                          | Worn or damaged cylinder barrel (101) and/or hydrodynamic bearing (202) running surface. |  |
|                          | Faulty circuit components (continuously blowing relief valve or a high-pressure leak).   | Eliminate leak or replace faulty components.   |
|                          | Insufficient pump inlet pressure.  | Consult appropriate pump specification for inlet pressure requirements.  |
|                          | Excessive fluid viscosity.   | Consult Application Guidelines (Bulletin 847085) for maximum viscosity limitations.  |
|                          | Insufficient pump inlet pressure.  | Eliminate any obstructions or other pressure drops in pump inlet plumbing. Consult appropriate pump specification for inlet pressure requirements. |
|                          | Pump input shaft rotating in wrong direction.  | Inspect and correct drive rotation.  |

## PRINCIPLE OF OPERATION

The illustrations show the pump driven clockwise (right hand) from the top (plan) view.

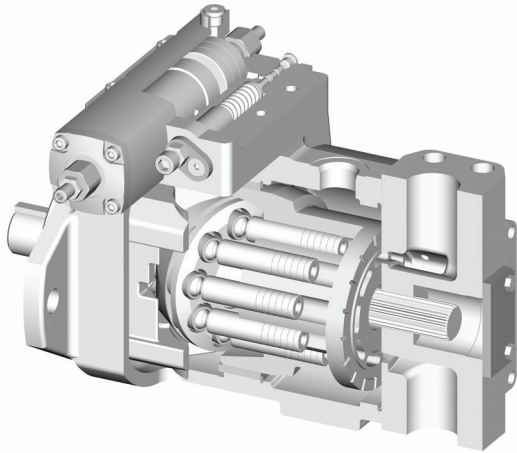

OILG0294

Figure 2. Cut-a-way of a Typical “PVWJ” Pump with Typical Control

## Position B, Pump During Full Delivery FROM PORT B - Figure 3

Rotating the drive shaft (301) clockwise turns the splined cylinder, which contains the pumping pistons (102). When the cylinder rotates, the pistons move in and out within their bores as the shoes ride against the angled (C) swashblock (201).

As the cylinder rotates, the individual piston bores are connected, alternately, to the crescent shaped upper (port A) and lower (port B) in the valve plate. While connected to the upper side (suction) port A, each piston moves outward **OUT**, drawing fluid from port A into the piston bore until its outermost stroke (D) is reached. At this point, the piston bore passes from the upper crescent port A to the lower crescent port B.

While rotating across the lower crescent, each piston moves across the angled swashblock face and then each piston is forced inward **IN**. Each piston then displaces fluid through the lower crescent to port B until its innermost stroke (D) is reached. At this point, the piston bore passes from the lower to the upper crescent again and the cycle is repeated.

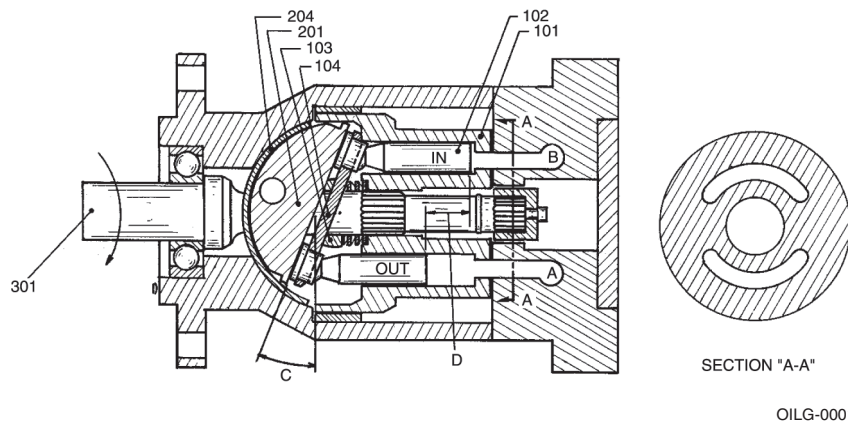

Figure 3. Position B, Pump During Full Delivery From Port B

**Position B/2, Pump During One Half Delivery FROM PORT B - Figure 4**

This illustration shows that the angle (E) of the swashblock determines the length of the piston stroke (F), (the difference between outermost and innermost position) which determines the amount of delivery from the pump. In this case, the stroke angle (E) is one-half of the stroke, which means the piston stroke is one-half and the pump delivery is one-half.

**Position N, Pump In Neutral, No Stroke, No Delivery - Figure 5**

Neutral position results when the control centers the swashblock. The swashblock angle (G) is now zero and swashblock face is parallel to the cylinder face. There is no inward or outward motion of the pump pistons as piston shoes rotate around the swashblock face. With no inward and outward motion or no stroke (H), **NEUTRAL** no fluid is being displaced from the piston bores to the crescents in the valve plate and there is no delivery from pump ports.

**NOTE** Illustration reference numbers match the part item number in the parts list.

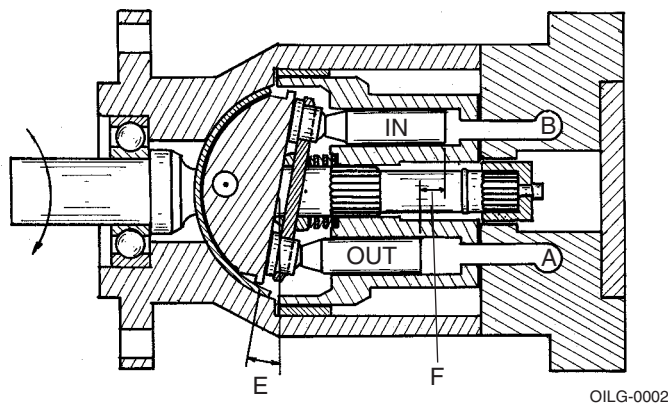

**Figure 4. Position B/2, Pump During One Half Delivery From Port B**

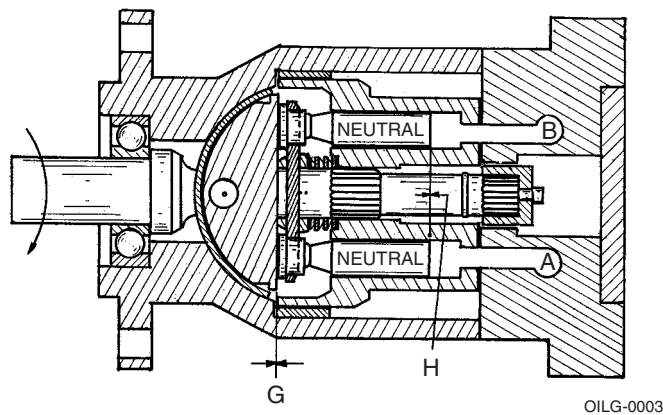

**Figure 5. Position N, Pump In Neutral, No Stroke, No Delivery**

## TESTING AND ADJUSTING

### PISTON PUMP

To check for a worn piston pump, make a leak measurement test from the case drain while the pump is under pressure. After the unit is warm, either install a flow meter in the drain line or have the flow from the drain line directed into a large container or reservoir. The pump case must remain full of fluid during this test.

#### WARNING

**Shut the pump OFF and release pressure from the system before disassembling components. Failure to comply with these instructions could result in personal injury or death. Blocking the pressure line between the pump and the system (or pump) high-pressure relief valve will result in damage and could result in serious personal injury.**

With an accurate high-pressure gauge in the pressure line, start the pump and stall (or block) output device to raise system pressure to maximum (as set by system relief valve). Read the measurement on the flow meter or time and measure the case drain flow used to fill a known size container and calculate the flow rate in terms of cubic inches per minute (cipm). The leakage should conform to **Table 4**.

#### CAUTION

**DO NOT run a pump on stroke against a blocked output unless it is protected by a high-pressure relief valve and then run no longer than necessary to check slip. Limit discharge to prevent dropping reservoir fluid below low level.**

#### NOTE

*Increasing shaft speed or a decrease in fluid viscosity will increase leakage. Manually or mechanically de-stroking the pump has a negligible effect on leakage.*

#### NOTE

*Additional leakage indicates wear, but does not become critical until it impairs performance.*

#### NOTE

*If testing a unit with a pressure compensator control, make sure the compensator setting is at least 500 psi above the pump outlet pressure to assure the pump is at full stroke.*

| Unit | Full Stroke Leakage @ Pump Outlet Pressure (psi) |      |          |     |          |     |          |     |          |     |          |     |
|------|--|------|----------|-----|----------|-----|----------|-----|----------|-----|----------|-----|
|      | 1500 psi   |      | 2500 psi |     | 3000 psi |     | 3500 psi |     | 4000 psi |     | 5000 psi |     |
|      | cipm   | lpm  | cipm     | lpm | cipm     | lpm | cipm     | lpm | cipm     | lpm | cipm     | lpm |
| 011  | 50   | 2.08 | 70       | 1.1 | 80       | 1.3 | 100      | 1.6 | 120      | 2.0 | 200      | 3.3 |
| 014  | 90   | 1.5  | 120      | 2.0 | 140      | 2.3 | 165      | 2.7 | 200      | 3.3 | -        | -   |
| 022  | 120  | 2.0  | 170      | 2.8 | 200      | 3.3 | -        | -   | -        | -   | -        | -   |
| 025  | 105  | 1.7  | 135      | 2.2 | 150      | 2.4 | 175      | 2.9 | 210      | 3.4 | 300      | 4.9 |
| 034  | 150  | 2.4  | 210      | 3.4 | 250      | 4.1 | 300      | 4.9 | -        | -   | -        | -   |
| 046  | 230  | 3.8  | 300      | 4.9 | -        | -   | -        | -   | -        | -   | -        | -   |
| 064  | 150  | 2.4  | 205      | 3.4 | 240      | 3.9 | 275      | 4.5 | 320      | 5.2 | 460      | 7.6 |
| 076  | 200  | 3.3  | 305      | 5.0 | 375      | 6.1 | 460      | 7.6 | -        | -   | -        | -   |
| 098  | 270  | 4.4  | 460      | 7.6 | -        | -   | -        | -   | -        | -   | -        | -   |
| 130  | 530  | 8.7  | -        | -   | -        | -   | -        | -   | -        | -   | -        | -   |

**Table 4. Nominal Case Slip at full stroke and 1800 RPM, fluid viscosity 160 SSU.**

## DISASSEMBLY

### NOTE

*The cleanliness of working on this pump or the hydraulic system is extremely important to the safety and reliability of the pump and the system.*

*When disassembling or assembling the pump, choose a clean, dry, dust and sand-free area where no traces of abrasive particles are in the air which can damage the pump and system. DO NOT work near welding, sandblasting, grinding benches or similar conditions.*

*Always make sure the fittings are clean on the outside before removing them from their connections. Make sure they are capped and plugged when removed. Place them on a clean surface and in a clean rag or container until they are reinstalled. When cleaning parts which have been disassembled, it is important to use CLEAN cleaning solvents and allow parts to dry. All tools and gauges should be clean prior to working with the system and use new, CLEAN, lint-free rags to handle and dry parts.*

### WARNING

**DO NOT attempt to remove or install any components or assembly while the pump and system is running. Always stop the pump, shut OFF the power and release pressure from the system before servicing or testing. Be sure provisions have been made so the case drain line can be disconnected from the unit without causing the line to drain (siphon) the reservoir.**

1. Disconnect case drain line from port **1** or **1A**.
2. Drain pump case through the remaining (port **1** or **1A**) on the bottom of case. If plugs are inaccessible, it may be necessary to remove the pump from the mounting and drive motor before draining it.
3. After removing the pump from the mounting and before disassembly, cap or plug all ports and clean the outside of unit thoroughly to prevent dust from entering the system. See **Figures 10** and **18**.

### NOTE

*Depending on what part or parts are to be inspected, it may not be necessary to completely take apart all assemblies.*

## CONTROL GROUP

Refer to the reference material for the information which applies to the control your pump is equipped with. Some force is required to remove the control housing.

1. Remove socket head cap screws.
2. Lift the control group assembly, with control pin, straight up from the top of the pump assembly. The control pin may or may not remain in the swashblock (**201**).
3. Remove control gasket and O-rings from the pump housing.

## VALVE PLATE GROUP

If another pump is coupled to thru-shaft pumps, remove coupling half before removing valve plate.

1. Block the pump on a bench with the drive shaft facing down.
2. If applicable, remove relief valve block from valve plate.
3. Remove the valve plate (**401**) by removing four hex head cap screws (**403**) and lifting it straight up.
4. Remove O-rings.



## ROTATING GROUP

### **⚠ WARNING**

The rotating group may be heavy. Be careful not to damage cylinder wear surface which mates against the valve plate, bearing diameters or piston shoes. Use proper lifting techniques and assistance from others to prevent personal injury.

1. Place the pump in a horizontal position.
2. Remove the rotating group by turning shaft (301) slowly, while pulling the cylinder barrel (101) from the housing.
3. Identify (number) each pump piston shoe assembly (102) and its respective bore in the cylinder barrel (101) and shoe retainer (104) for easy reassembly.
4. See **Figure 6**. Lift out shoe retainer (104) with pistons (102) and remove the fulcrum ball (103) and shoe retainer spring (105).

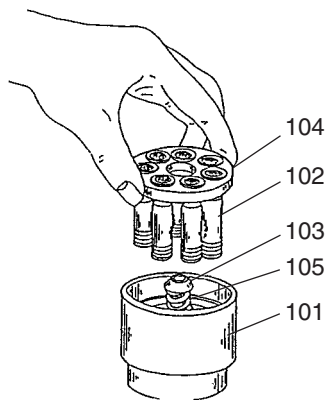

OILG-0004

**Figure 6. Rotating Group Disassembly.**

5. Remove retaining ring (208) and pull the hydrodynamic bearing (202) and roll pins, if necessary, (205) from the housing. Note the position of roll pin (205) inside of case.

## DRIVE SHAFT GROUP

1. Remove the drive key (303), if used and the drive shaft bearing retainer ring (305).
2. Grasp outboard end of drive shaft (301) and pull it out of the pump housing.
3. Remove the shaft seal retainer (302) and shaft seal (007) from the housing only if necessary.

## SWASHBLOCK GROUP

1. Reach inside the housing and remove the swashblock (201) and saddle bearings (204).
2. If applicable, remove the saddle block (216) from the housing.

## INSPECTION

Clean all parts thoroughly and allow them to dry. Inspect all seals and O-rings for hardening, cracking or deterioration. Replace if necessary or if you suspect damage. Check all locating pins for damage and springs for cracking or signs of cracking or signs of wear.

### **⚠ WARNING**

Wear proper protective gear when using solvents or compressed air, servicing or maintaining the hydraulic system or the Oilgear pump. Wear correct protective gear, safety glasses, gloves and safety shoes. Serious injury can result without proper protective gear.

## CONTROL GROUP

Refer to the reference material on pump controls. Be sure to carefully check the control pin for cracks and/or signs of fatigue. Check fit of the pin in the swashblock. It should be a slip-fit without side-play. Replace if necessary or if you suspect damage.

## VALVE PLATE GROUP

Inspect the valve plate (401) surface which mates with the cylinder barrel (101) for excessive wear or scoring. Remove minor defects by lightly stoning the surface with a hard stone which is flat to within 0.001 inches (0,025 mm).

**NOTE** *Be sure to stone lightly. Any excessive stoning will remove the hardened surface. If wear or damage is extensive, replace the valve plate.*

## ROTATING GROUP

Inspect cylinder barrel (101) piston bores and the face which mate with the valve plate for wear and scoring. Remove minor defects on the face by lightly stoning or lapping the surface.

Inspect the cylinder bearing (202) for damage and replace if necessary. Check all piston and shoe assemblies (102) to be sure they ride properly on the swashblock.

**NOTE** *Be sure to stone lightly. Any excessive stoning will remove the hardened surface. If wear or damage is extensive and defects cannot be removed, replace the cylinder barrel.*

See **Figure 7**. Check each shoe face for nicks and scratches, and the shoe for smooth pivot action on the piston.

**NOTE** *If one or more piston/shoe assembly needs to be replaced, replace all the piston/shoe assemblies. When installing new piston/shoe assemblies or the rotating group, make sure the pistons move freely in their respective bores.*

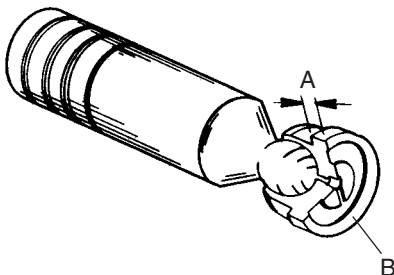

OILG-0005

**Figure 7. Piston and Shoe Inspection**

- (A) All shoes must be equal within 0.001 inches (0,025 mm) at this dimension.
- (B) All shoe faces must be free of nicks.

**NOTE** *End play should not to exceed 0.003 inches (0,076 mm) when new or 0.006 inches (0,152 mm) when worn.*

## SWASHBLOCK GROUP

Inspect the swashblock (201) for wear and scoring. If defects are minor, stone the swashblock lightly. If damage is extensive, replace the swashblock.

Check the small hole in the face of the swashblock. The hole provides “porting” for the hydrostatic balance fluid of the piston/shoe assembly to be channeled through the swashblock to the face of the saddle bearing, providing pressure lubrication.

Compare the saddle bearing (204) thickness in a worn area to thickness in an unworn area. Replace saddle bearings if the difference is greater than 0.015 inches (0,4 mm).

Check the mating surface of swashblock for cracks or excessive wear. The swashblock movement in the saddle bearings must be smooth. Replace if necessary.

**NOTE** *Be sure to stone lightly. Any excessive stoning will remove the hardened surface. If wear or damage is extensive and defects cannot be removed, replace if necessary or if you suspect them of being bad.*

## DRIVE SHAFT GROUP

Check:

- the shaft seal (007) for deterioration or cracks. Replace if necessary (push-out).
- the shaft bearing (306) for galling, pitting, binding or roughness.
- the rear shaft bushing in valve plate.
- the shaft and its splines for wear. Replace any parts necessary.
- for grooving of the shaft where the shaft seal contacts it.

## ASSEMBLY

See **Figures 8, 9 and 10**. Follow the disassembly procedures in reverse for re-assembling the pump.

During assembly, install new seals and O-rings. Apply a thin film of CLEAN grease or hydraulic fluid to sealing components to ease assembly. If a new rotating group is used, lubricate thoroughly with CLEAN hydraulic fluid. Apply fluid generously to all wear surfaces.

### SWASHBLOCK GROUP

If removed,

1. Press shaft seal **(007)** into front of pump housing.
2. Place housing on a bench with the mounting flange side down.
3. If applicable, install the saddle block **(216)** into the housing. Make sure the anti-rotating pin **(217)** aligns the saddle block correctly.
4. Grease the back side of each saddle bearing **(204)** and place on the pin to locate the bearings in the pump case. Make sure the pins do not protrude.
5. Insert swashblock **(201)** into the pump housing. Once in place, be sure the swashblock swivels in the saddle bearings. With new bearings, swiveling may be stiff and not always smooth.
6. Make sure the roll pin **(205)** is inserted into the cylinder bearing **(202)**. Position the cylinder bearing so the pin is located at the same location as it was when the pump was disassembled. The bearing should fit into place with a little difficulty and be square to the axis of the pump.
7. Tap bearing into place if necessary using extreme care not to damage the bearing.
8. Insert retaining ring **(208)** to hold bearing in place.

**NOTE** Refer to **Figure 8** and **Figure 9** for the correct orientation of the pins for the appropriate frame size.

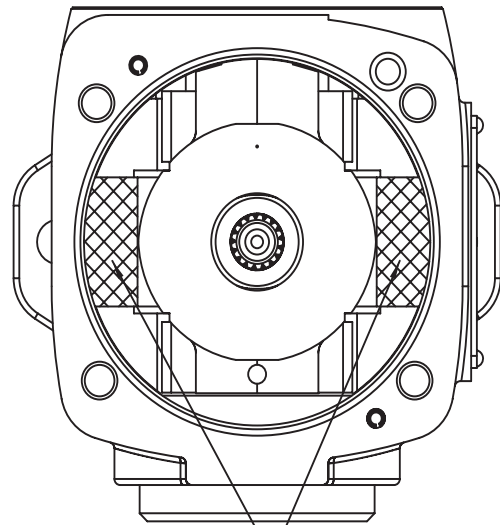

Hydrobearing anti-rotation pin must be inserted into either of these recesses.

OILG0305

**Figure 8. A-Frame Orientation of Pins**

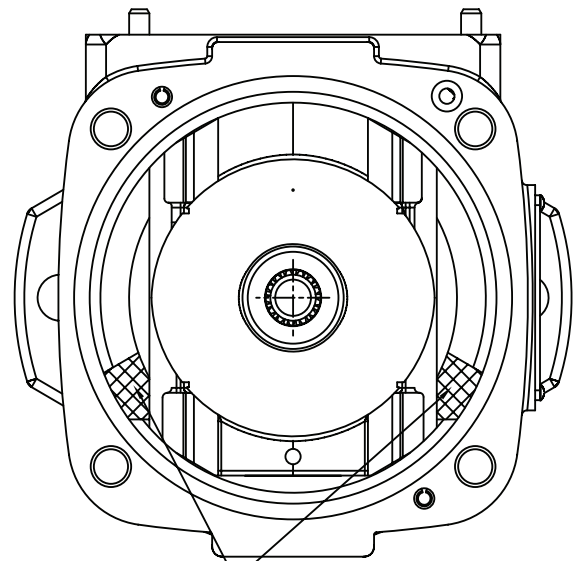

Hydrobearing anti-rotation pin must be inserted into either of these recesses.

OILG0306

**Figure 9. B-Frame and C-Frame Orientation of Pins**

## DRIVE SHAFT GROUP

1. Place the housing on its side with the axis horizontal.
2. Install the seal retainer (302).
3. Lubricate the shaft seal (007) and shaft.
4. Insert the drive shaft (301) and bearing assembly into the housing.
5. Lock in place with the drive shaft bearing retainer ring (305).

## ROTATING GROUP

See Figure 6.

1. Place the cylinder barrel (101), wear surface down, on a clean cloth.
2. Place the shoe retainer spring (105) in the center of the barrel with the fulcrum ball (103) on top of it.
3. Insert the identified pistons (102) into their corresponding identified holes of the shoe retainer (104). As a unit, fit the pistons into their corresponding, identified bores in the cylinder barrel. **DO NOT FORCE.** If everything is aligned properly, the pistons will fit smoothly.

### **WARNING**

**The rotating group weight may be heavy. Be careful not to damage cylinder wear surface which mates against the valve plate, bearing diameters or piston shoes. Use proper lifting techniques and assistance from others to prevent personal injury.**

The rotating group can now be carefully installed over the tail of the drive shaft (301) and into the pump housing (001).

#### **NOTE**

*When installing the rotating group, support the weight of the cylinder barrel (101), as cylinder spline is passed over the tailshaft, to avoid scratching or damage.*

4. Push cylinder forward until the cylinder spline reaches the drive shaft spline and rotate slightly to engage shaft splines. Continue to slide cylinder forward until it encounters the cylinder bearing (202). Lifting the tailshaft slightly helps the cylinder (101) and the cylinder bearing (202) engagement. Continue pushing the cylinder forward until the piston shoes contact the swashblock. The back of the

cylinder should slightly protrude outside the back of the pump housing.

5. Install and torque the four control screws to the appropriate value shown in **Table 5**.

## RELIEF VALVE BLOCK

1. Install new O-rings on the relief block.
2. Position the relief valve block over the outlet port of the valve plate.
3. Install and torque the four screws to the appropriate value shown in **Table 5**.

## VALVE PLATE GROUP

1. Place the partially assembled pump housing on a bench with the open end facing up.
2. Install new O-rings on the housing.
3. Position the valve plate (401) over the tailshaft and on pins (005) and housing.
4. Install and torque the four valve plate screws to the appropriate value shown in **Table 5**.
5. If any plugs were removed, reinstall and torque them to the appropriate value shown in **Table 5**.

## CONTROL GROUP

1. Place the assembled pump on its side with the axis horizontal.
2. Install new O-rings on the housing.
3. Install the control pin into the swashblock.
4. Position the control assembly so the control pin fits into the annular slot of the control piston.
5. Assemble the control assembly to the pump assembly, making sure that both alignment pins (006) are correctly inserted into their respective holes of the control body.

#### **NOTE**

*It may be necessary to mechanically position the control piston to correctly align the control on the pump.*

## PVWJ PUMP TORQUES

|   | Item Number | Description                                       | Head Type & Size                           | Tightening Torque    |
|---|-------------|---|--|----------------------|
| A-Frame<br>PVWJ-011<br>PVWJ-014<br>PVWJ-022             | 002         | Housing Plug                                      | 3/4" Internal Hex                          | 100 ft-lbs (136 N·m) |
|   | 403         | Valve Plate Screws                                | 3/8" Internal Hex or<br>9/16" External Hex | 15 ft-lbs (20 N·m)   |
|   | 507         | Tandem Cover Screws                               | 1/2" Internal Hex                          | 325 in.-lbs (5 N·m)  |
|   | 601         | SAE #2 Plug                                       | 1/8" Internal Hex                          | 45 in.-lbs (5 N·m)   |
|   | 626         | SAE #10 Plug                                      | 1" External Hex                            | 90 ft-lbs (122 N·m)  |
| B-Frame<br>PVWJ-025<br>PVWJ-034<br>PVWJ-046             | 403         | Valve Plate Screws                                | 3/4" External Hex                          | 37 in.-lbs (50 N·m)  |
|   | 405         | SAE #2 Plug                                       | 1/8" Internal Hex                          | 45 in.-lbs (5 N·m)   |
|   | 503         | SAE A Tandem Mounting Screws                      | 9/16" External Hex                         | 28 ft-lbs (38 N·m)   |
|   |             | SAE B Tandem Mounting Screws                      | 3/4" External Hex                          | 37 ft-lbs (50 N·m)   |
|   | 507         | Cover Plate or Adapter Screws                     | 1/2" External Hex                          | 325 in.-lbs (37 N·m) |
|   | 902         | Relief Valve Block Screws                         | 3/8" Internal Hex                          | 44 ft-lbs (60 N·m)   |
| C-Frame<br>PVWJ-064<br>PVWJ-076<br>PVWJ-098<br>PVWJ-130 | 403         | Valve Plate Screws                                | 14 mm Internal Hex                         | 56 ft-lbs (76 N·m)   |
|   | 503         | SAE A Tandem Mounting Screws                      | 9/16" External Hex                         | 28 ft-lbs (38 N·m)   |
|   |             | SAE B Tandem Mounting Screws                      | 3/4" External Hex                          | 37 ft-lbs (50 N·m)   |
|   |             | SAE C Tandem Mounting Screws                      | 15/16" External Hex                        | 74 ft-lbs (100 N·m)  |
|   | 507         | Cover Plate Screws                                | 1/2" External Hex                          | 325 in.-lbs (37 N·m) |
|   |             | Adapter Screws                                    | 9/16" External Hex                         | 28 ft-lbs (38 N·m)   |
|   | 601         | SAE #2 Plug                                       | 1/8" Internal Hex                          | 45 in.-lbs (5 N·m)   |
|   | 902         | Relief Valve Block Screws<br>(PVWH-076/-098/-130) | 3/8" Internal Hex                          | 68 ft-lbs (92 N·m)   |
|   |             | Relief Valve Block Screws<br>(PVWH-064)           | 1/2" Internal Hex                          | 138 ft-lbs (187 N·m) |

**Table 5. PVWJ Pump Assembly Torques**

## CONTROL O-RING SEALS

| Item Number | ARP 568 Uniform Size Number | Shore A Durometer |
|-------------|-----------------------------|-------------------|
| 1008        | 008                         | 70                |
| 1010        | 010                         | 90                |
| 1012        | 012                         | 90                |
| 1042        | 042                         | 70                |
| 1138        | 138                         | 70                |
| 1145        | 145                         | 70                |
| 1155        | 155                         | 70                |
| 1159        | 159                         | 70                |
| 1219        | 219                         | 90                |
| 1222        | 222                         | 90                |
| 1225        | 225                         | 90                |
| 1228        | 228                         | 90                |
| 1237        | 237                         | 70                |
| 1242        | 242                         | 70                |
| 1252        | 252                         | 70                |
| 1257        | 257                         | 70                |
| 1500        | See note 1                  | 80                |
| 1902        | 902                         | 90                |
| 1910        | 910                         | 90                |

**Note 1.** 94 mm OD x 2.5 mm

**Table 6. PVWJ Pump O-Ring Seals**



---

## **NOTES**

---

---

---

---

---

---

---

---

---

---

---

---

---

---

---

---

---

---

---

---

---

---

---

---

---

---

---

---

---

---

# PVWJ-011/-014/-022 A-Frame

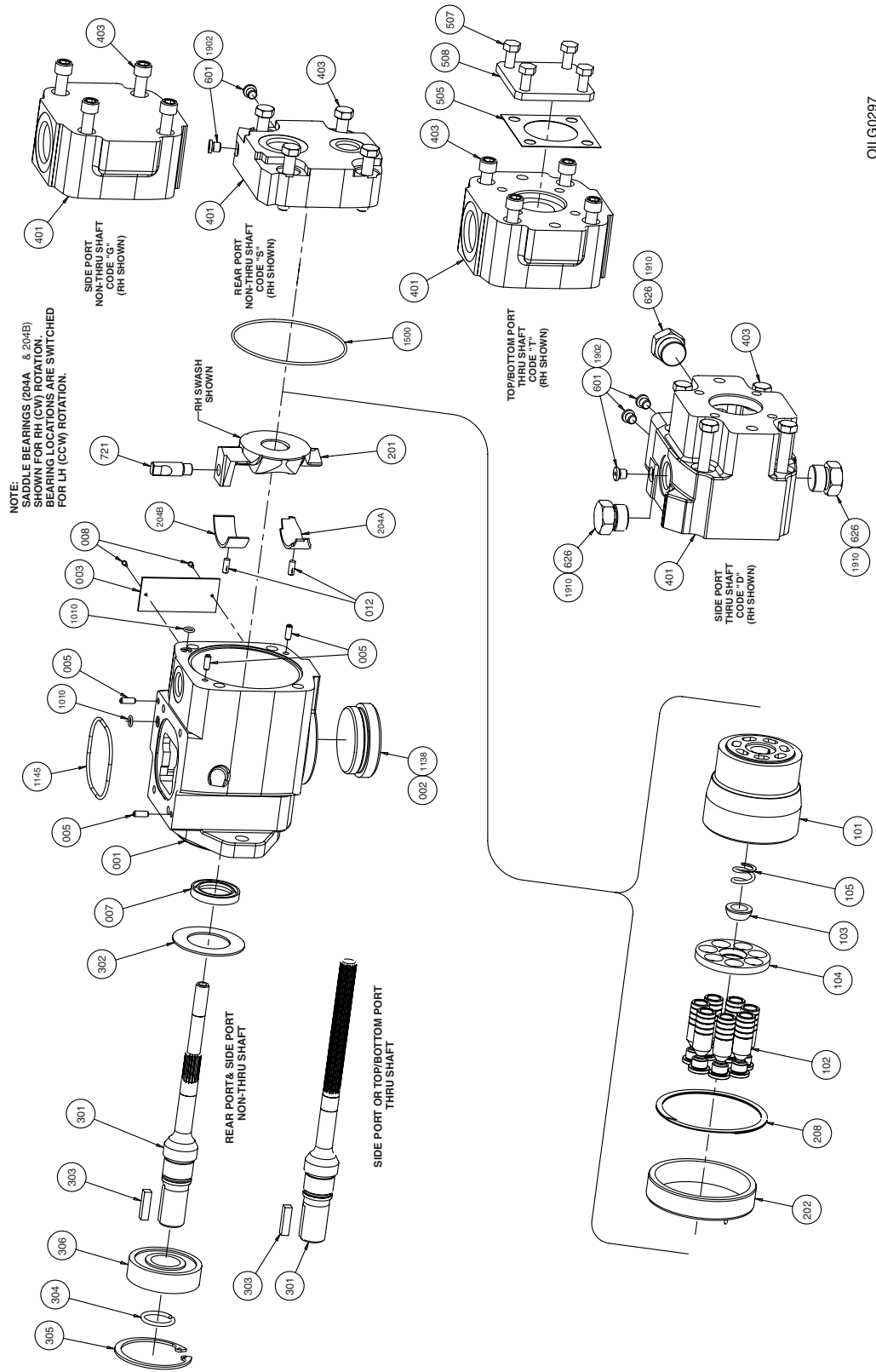

OILG0297

Figure 10. Exploded parts drawing, PVWJ-011/-014/-022 A-Frame (520024-101 sheet 2 of 4).

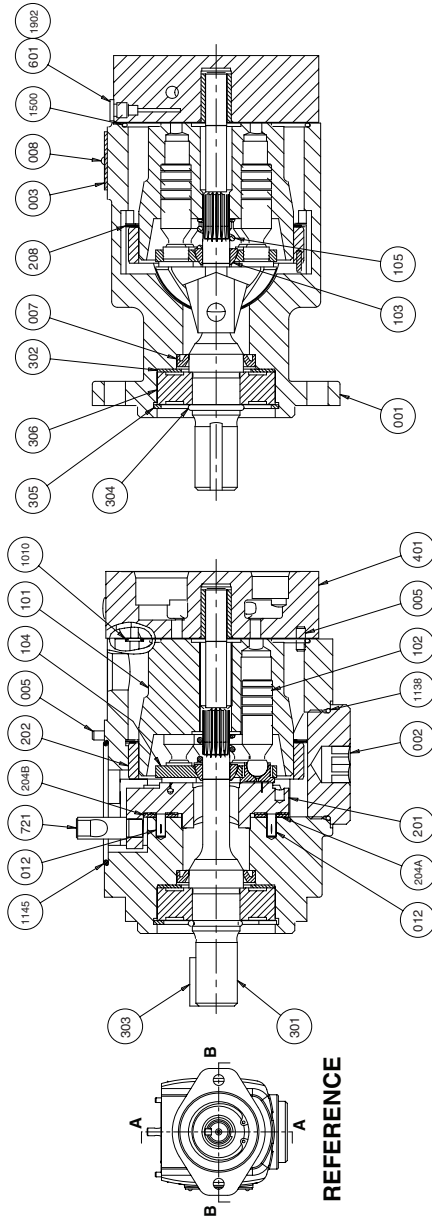

OILG0296

VIEW B-B

VIEW A-A

Figure 11. Cross section and plan view parts drawing, PVWJ-011/-014/-022 A-Frame (520024-101 sheet 1 of 4).

**PVWJ-011/-014/-022 A-FRAME PUMP PARTS LIST**

Parts used in these assemblies are per Oilgear specifications. Use only Oilgear parts to ensure compatibility with assembly requirements. When ordering replacement parts, be sure to include pump type and serial number, bulletin number and item number. Specify type of hydraulic fluid to ensure seal and packing compatibility.

**NOTE** Parts drawings may not be identical to Oilgear drawings referenced.

| Item                          | Qty | Description  |
|-------------------------------|-----|--------------|
| <b>HOUSING ASSEMBLY GROUP</b> |     |              |
| 001                           | 1   | Pump Housing |
| 002                           | 1   | Plug         |
| 003                           | 1   | Name Tag     |
| 005                           | 4   | Roll Pin     |
| 007                           | 1   | Shaft Seal   |

|                                  |   |                                |
|----------------------------------|---|--------------------------------|
| 008                              | 2 | Drive Screws                   |
| 012                              | 2 | Saddle Bearing Locating Pin    |
| 1010                             | 2 | O-Ring                         |
| 1138                             | 1 | O-Ring                         |
| 1145                             | 1 | O-Ring                         |
| 1500                             | 1 | O-Ring                         |
| <b>ROTARY ASSEMBLY GROUP</b>     |   |                                |
| 101                              | 1 | Barrel                         |
| 102                              | 7 | Piston & Shoe Assembly         |
| 103                              | 1 | Fulcrum Ball                   |
| 104                              | 1 | Shoe Retainer                  |
| 105                              | 1 | Shoe Retainer Spring           |
| <b>SWASHBLOCK ASSEMBLY GROUP</b> |   |                                |
| 201                              | 1 | Swashblock                     |
| 202                              | 1 | Hydrodynamic Bearing           |
| 204A                             | 1 | Saddle Bearing (pressure side) |
| 204B                             | 1 | Saddle Bearing (suction side)  |
| 208                              | 1 | Retaining Ring                 |
| 721                              | 1 | Control Pin                    |

|                                   |        |                             |
|-----------------------------------|--------|-----------------------------|
| <b>DRIVE SHAFT ASSEMBLY GROUP</b> |        |                             |
| 301                               | 1      | Drive Shaft                 |
| 302                               | 1      | Seal Retainer               |
| 303                               | 1      | Key                         |
| 304                               | 1      | Shaft Retainer Ring         |
| 305                               | 1      | Shaft Bearing Retainer Ring |
| 306                               | 1      | Front Drive Shaft Bearing   |
| <b>VALVE PLATE ASSEMBLY GROUP</b> |        |                             |
| 401                               | 1      | Valve Plate                 |
| 403                               | 4      | Screw                       |
| 601                               | Note 1 | Plug                        |
| 626                               | Note 1 | Plug                        |
| 1902                              | Note 1 | O-Ring                      |
| 1910                              | Note 1 | O-Ring                      |
| <b>COVER PLATE PARTS</b>          |        |                             |
| 505                               | 1      | Gasket                      |
| 507                               | 4      | Screw                       |
| 508                               | 1      | Cover Plate                 |

**Note 1.** Qty is 0, 1, 2 or 3 dependent on Valve Plate type.

THRU-SHAFT COUPLINGS

CODE "D" ASSEMBLY (TOP VIEW)  
SHOWN W/ L51447-008 COUPLING

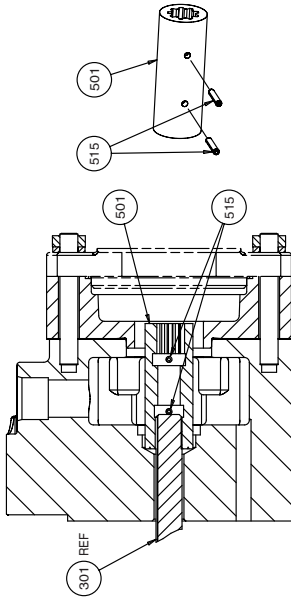

CODE "T" ASSEMBLY (SIDE VIEW)  
SHOWN W/ L51447-008 COUPLING

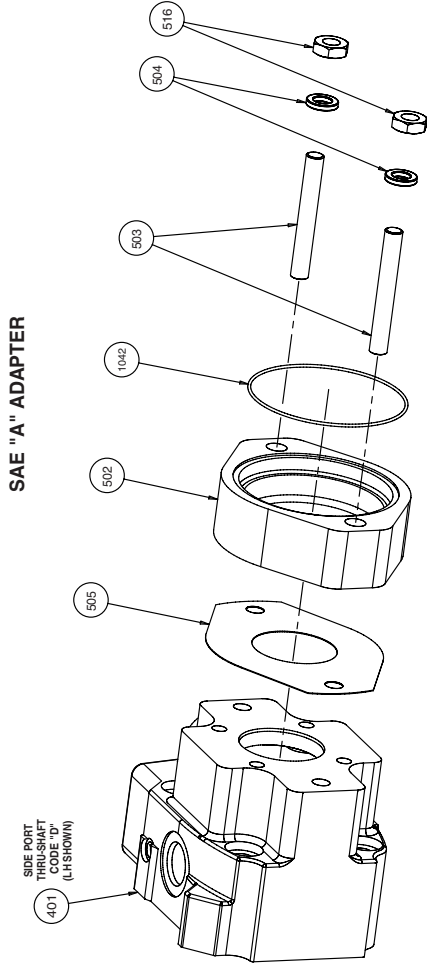
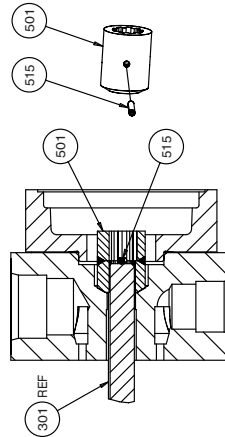

SAE "A" ADAPTER

OILG0298

Figure 12. Exploded parts drawing, PVWJ-011/-014/-022 A-Frame, Thru-Shaft Couplings and SAE "A" Adapter (520024-101 sheet 3 of 4).

| Item                              | Qty. | Description |
|-----------------------------------|------|-------------|
| <b>DRIVE SHAFT ASSEMBLY GROUP</b> |      |             |
| 301                               | 1    | Drive Shaft |
| <b>VALVE PLATE ASSEMBLY GROUP</b> |      |             |
| 401                               | 1    | Valve Plate |

| <b>DUAL PUMP ADAPTER PARTS</b> |   |          |
|--------------------------------|---|----------|
| 501                            | 1 | Coupling |
| 502                            | 1 | Adapter  |
| 503                            | 2 | Stud     |
| 504                            | 2 | Washer   |
| 505                            | 1 | Gasket   |
| 515                            | 1 | Roll Pin |
| 516                            | 2 | Hex Nut  |
| 1042                           | 1 | O-Ring   |

Document Number: 520024-SK1

Reference 520024-101  
SERVICE KIT Drawings figures 10-12

Revision: New

**SERVICE KITS**  
PVWJ A-Frame Units (PVWJ-011/-014/-022)

| Description  | Kit No.    | Design Series | Items Included (quantity is 1 unless noted) |
|--|------------|---------------|---|
| <b>Housing Kits</b>                                    |            |               |   |
| All Models   | L51116-30  | A1            | 001, 005(4), 007, 012, 1010(2), 1145, 1500  |
| <b>Rotating Group Bearing Kit</b>                      |            |               |   |
| All Models   | L51203-1   | A1            | 202, 208                                    |
| <b>Shaft &amp; Bearing Kits</b>                        |            |               |   |
| Kits for Non Thru-Shaft Models                         |            |               |   |
| 3/4" Dia. Keyed (Code "Y")                             | L51128-11  | A1            | 301, 302, 303, 304, 305, 306                |
| 7/8" Dia. Keyed (Code "B")                             | L51128-15  | A1            | 301, 302, 303, 304, 305, 306                |
| 5/8" 9T SAE Spline (Code "S")                          | L51128-13  | A1            | 301, 302, 304, 305, 306                     |
| 7/8" 13T Industrial Spline (Code "C")                  | L51128-17  | A1            | 301, 302, 304, 305, 306                     |
| Kits for Thru-Shaft Models with Code "DA" Valve Plates |            |               |   |
| 3/4" Dia. Keyed (Code "Y")                             | L51518-11A | A1            | 301, 302, 303, 304, 305, 306                |
| 7/8" Dia. Keyed (Code "B")                             | L51518-11  | A1            | 301, 302, 303, 304, 305, 306                |
| 5/8" 9T SAE Spline (Code "S")                          | L51518-10  | A1            | 301, 302, 304, 305, 306                     |
| 5/8" 9T Industrial Spline (Code "D")                   | L51518-12Z | A1            | 301, 302, 304, 305, 306                     |
| 7/8" 13T Industrial Spline (Code "C")                  | L51518-12  | A1            | 301, 302, 304, 305, 306                     |
| Kits for Thru-Shaft Models with Code "TA" Valve Plates |            |               |   |
| 3/4" Dia. Keyed (Code "Y")                             | L51518-33A | A1            | 301, 302, 303, 304, 305, 306                |
| 7/8" Dia. Keyed (Code "B")                             | L51518-39A | A1            | 301, 302, 303, 304, 305, 306                |
| 5/8" 9T SAE Spline (Code "S")                          | L51518-35A | A1            | 301, 302, 304, 305, 306                     |
| 5/8" 9T Industrial Spline (Code "D")                   | L51518-37A | A1            | 301, 302, 304, 305, 306                     |
| 7/8" 13T Industrial Spline (Code "C")                  | L51518-57  | A1            | 301, 302, 304, 305, 306                     |
| <b>Swashblock Kits</b>                                 |            |               |   |
| LH (CCW) Models  | L50488-3   | A1            | 201, 721                                    |
| RH (CW) Models   | L50488-5   | A1            | 201, 721                                    |
| <b>Rotating Group Kits</b>                             |            |               |   |
| PVWJ-011   | L50052-8   | A1            | 101, 102(7), 103, 104, 105                  |
| PVWJ-014   | L50052-7   | A1            | 101, 102(7), 103, 104, 105                  |
| PVWJ-022   | L50053-7   | A1            | 101, 102(7), 103, 104, 105                  |
| <b>Saddle Bearing Kit</b>                              |            |               |   |
| All Models   | L51053-4   | A1            | 204A, 204B                                  |

| Valve Plate Kits                             |            |    |   |
|--|------------|----|---|
| <b>PVWJ-011</b>                              |            |    |   |
| LH Rear Port (Code "SA")                     | K51101-500 | A1 | 401, 403(4), 601(2), 1010, 1500, 1902(2)                  |
| RH Rear Port (Code "SA")                     | K51101-501 | A1 | 401, 403(4), 601(2), 1010, 1500, 1902(2)                  |
| LH Side Port, Non Thru-Shaft (Code "GA")     | K51101-502 | A1 | 401, 403(4), 650(2), 1010, 1500                           |
| RH Side Port, Non Thru-Shaft (Code "GA")     | K51101-503 | A1 | 401, 403(4), 650(2), 1010, 1500                           |
| LH Side Port, Thru-Shaft (Code "DA")         | K51101-504 | A1 | 401, 403(4), 601(2), 626(3), 1010, 1500, 1902(2), 1910(3) |
| RH Side Port, Thru-Shaft (Code "DA")         | K51101-505 | A1 | 401, 403(4), 601(2), 626(3), 1010, 1500, 1902(2), 1910(3) |
| LH Top/Bottom Port, Thru-Shaft (Code "TA")   | K51101-506 | A1 | 401, 403(4), 650(2), 1010, 1500                           |
| RH Top/Bottom Port, Thru-Shaft (Code "TA")   | K51101-507 | A1 | 401, 403(4), 650(2), 1010, 1500                           |
| <b>PVWJ-014</b>                              |            |    |   |
| LH Rear Port (Code "SA")                     | K51101-508 | A1 | 401, 403(4), 601(2), 1010, 1500, 1902(2)                  |
| RH Rear Port (Code "SA")                     | K51101-509 | A1 | 401, 403(4), 601(2), 1010, 1500, 1902(2)                  |
| LH Side Port, Non Thru-Shaft (Code "GA")     | K51101-510 | A1 | 401, 403(4), 650(2), 1010, 1500                           |
| RH Side Port, Non Thru-Shaft (Code "GA")     | K51101-511 | A1 | 401, 403(4), 650(2), 1010, 1500                           |
| LH Side Port, Thru-Shaft (Code "DA")         | K51101-512 | A1 | 401, 403(4), 601(2), 626(3), 1010, 1500, 1902(2), 1910(3) |
| RH Side Port, Thru-Shaft (Code "DA")         | K51101-513 | A1 | 401, 403(4), 601(2), 626(3), 1010, 1500, 1902(3), 1910(3) |
| LH Top/Bottom Port, Thru-Shaft (Code "TA")   | K51101-514 | A1 | 401, 403(4), 650(2), 1010, 1500                           |
| RH Top/Bottom Port, Thru-Shaft (Code "TA")   | K51101-515 | A1 | 401, 403(4), 650(2), 1010, 1500                           |
| <b>PVWJ-022</b>                              |            |    |   |
| LH Rear Port (Code "SA")                     | K51101-516 | A1 | 401, 403(4), 601(2), 1010, 1500, 1902(2)                  |
| RH Rear Port (Code "SA")                     | K51101-517 | A1 | 401, 403(4), 601(2), 1010, 1500, 1902(2)                  |
| LH Side Port, Non Thru-Shaft (Code "GA")     | K51101-518 | A1 | 401, 403(4), 650(2), 1010, 1500                           |
| RH Side Port, Non Thru-Shaft (Code "GA")     | K51101-519 | A1 | 401, 403(4), 650(2), 1010, 1500                           |
| LH Side Port, Thru-Shaft (Code "DA")         | K51101-520 | A1 | 401, 403(4), 601(2), 626(3), 1010, 1500, 1902(2), 1910(2) |
| RH Side Port, Thru-Shaft (Code "DA")         | K51101-521 | A1 | 401, 403(4), 601(3), 626(3), 1010, 1500, 1902(2), 1910(3) |
| LH Top/Bottom Port, Thru-Shaft (Code "TA")   | K51101-522 | A1 | 401, 403(4), 650(2), 1010, 1500                           |
| RH Top/Bottom Port, Thru-Shaft (Code "TA")   | K51101-523 | A1 | 401, 403(4), 650(2), 1010, 1500                           |
| <b>Pump Seal Kit</b>                         |            |    |   |
| All models                                   | L50824-24  | A1 | 007, 1010(2), 1138, 1145, 1500, 1902(3), 1910(3)          |
| <b>Piston &amp; Shoe Kits</b>                |            |    |   |
| PVWJ-011                                     | L51363-900 | A1 | 102(7)  |
| PVWJ-014                                     | L50021-900 | A1 | 102(7)  |
| PVWJ-022                                     | L50021-901 | A1 | 102(7)  |
| <b>Shoe Retainer &amp; Holddown Ball Kit</b> |            |    |   |
| All models                                   | L50019     | A1 | 103, 104  |
| <b>Tag Kit</b>                               |            |    |   |
| All models                                   | L50921     | A1 | 003, 008(2)   |



|  |            |    |  |  |  |
|--|------------|----|--|--|--|
| <b>Control Pin</b>                     |            |    |  |  |  |
| All models                             | 50623-5    | A1 | 721  |  |  |
| <b>Cover Plate Kit</b>                 |            |    |  |  |  |
| All models                             | L50671     | A1 | 505, 507(4), 508                                   |  |  |
| <b>Coupling &amp; Adapter Kits</b>     |            |    |  |  |  |
| All models using code "DA" Valve Plate | L51081-48  | A1 | 501, 502, 503(2), 504(2), 505, 506, 515(2), 516(2) |  |  |
| All models using code "TA" Valve Plate | L51081-113 | A1 | 501, 502, 503(2), 504(2), 505, 506, 515, 516(2)    |  |  |

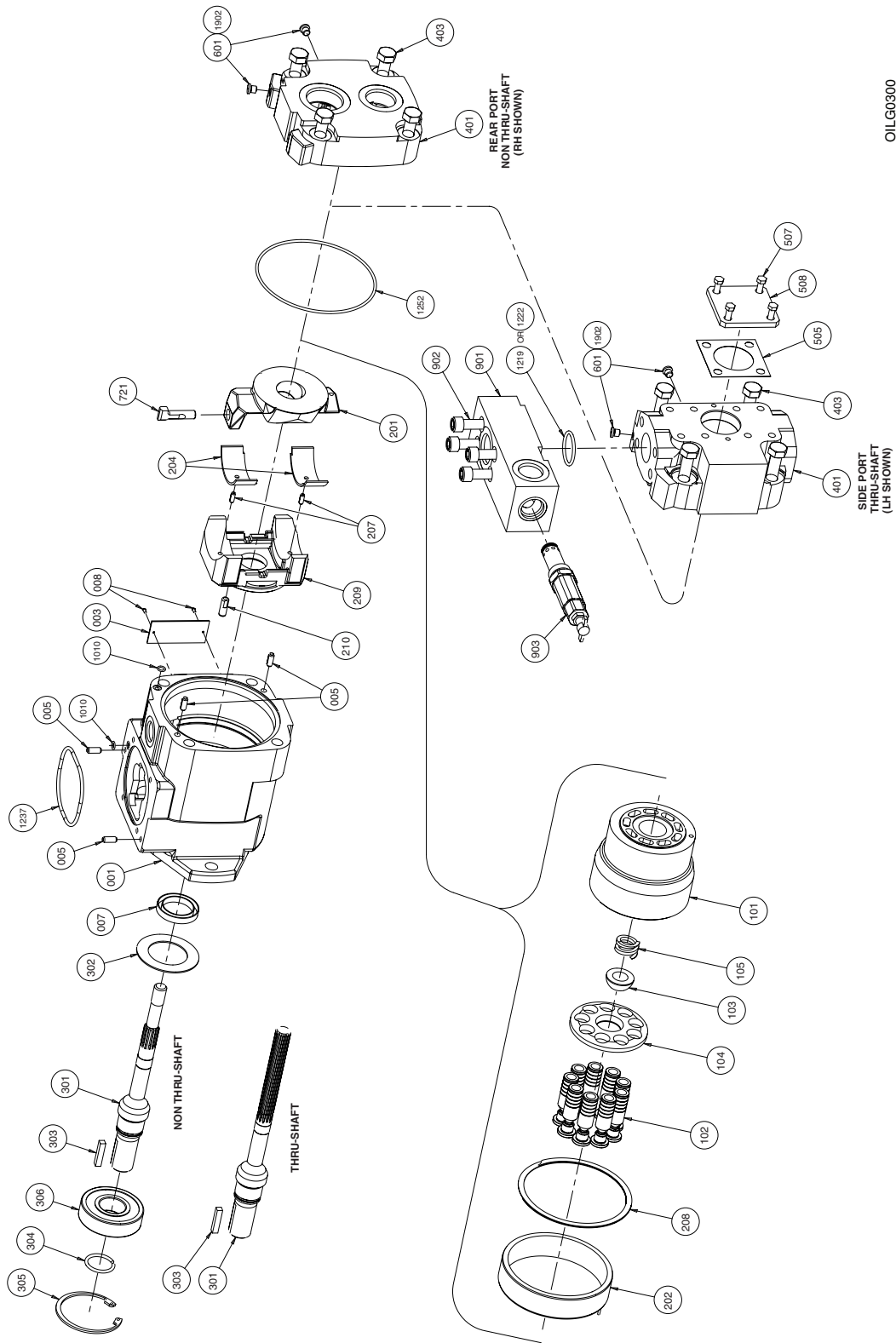

OILG0300

Figure 13. Exploded parts drawing, PVWJ-025/-034/-046 B-Frame (520024-201 sheet 2 of 4).

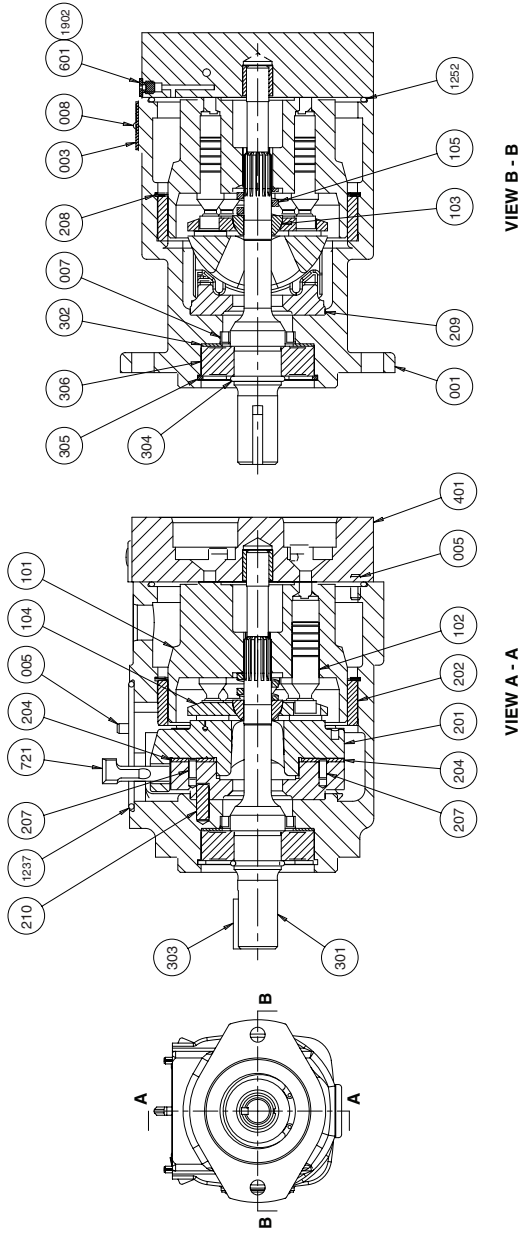

OILG0299

Figure 14. Cross section and plan view parts drawing, PVWJ-025/-034/-046 B-Frame (520024-201 sheet 1 of 4).

### PVWJ-025/-034/-046 B-FRAME PUMP PARTS LIST

| Item                          | Qty. | Description            |
|-------------------------------|------|------------------------|
| <b>HOUSING ASSEMBLY GROUP</b> |      |                        |
| 001                           | 1    | Pump Housing           |
| 003                           | 1    | Name Tag               |
| 005                           | 4    | Roll Pin               |
| 007                           | 1    | Shaft Seal             |
| 008                           | 2    | Drive Screws           |
| 1010                          | 2    | O-Ring                 |
| 1237                          | 1    | O-Ring                 |
| 1252                          | 1    | O-Ring                 |
| <b>ROTARY ASSEMBLY GROUP</b>  |      |                        |
| 101                           | 1    | Barrel                 |
| 102                           | 9    | Piston & Shoe Assembly |
| 103                           | 1    | Fulcrum Ball           |
| 104                           | 1    | Shoe Retainer          |
| 105                           | 1    | Shoe Retainer Spring   |

|                                   |   |                             |
|-----------------------------------|---|-----------------------------|
| <b>SWASHBLOCK ASSEMBLY GROUP</b>  |   |                             |
| 201                               | 1 | Swashblock                  |
| 202                               | 1 | Hydrodynamic Bearing        |
| 204                               | 2 | Saddle Bearing              |
| 207                               | 2 | Saddle Bearing Locating Pin |
| 208                               | 1 | Retaining Ring              |
| 209                               | 1 | Saddle Block                |
| 210                               | 1 | Saddle Block Locating Ring  |
| 721                               | 1 | Control Pin                 |
| <b>DRIVE SHAFT ASSEMBLY GROUP</b> |   |                             |
| 301                               | 1 | Drive Shaft                 |
| 302                               | 1 | Seal Retainer               |
| 303                               | 1 | Key                         |
| 304                               | 1 | Shaft Retainer Ring         |
| 305                               | 1 | Shaft Bearing Retainer Ring |
| 306                               | 1 | Front Drive Shaft Bearing   |
| <b>VALVE PLATE ASSEMBLY GROUP</b> |   |                             |
| 401                               | 1 | Valve Plate                 |
| 403                               | 4 | Screw                       |
| 601                               | 2 | Plug                        |
| 1902                              | 2 | O-Ring                      |

|   |   |                        |
|---|---|------------------------|
| <b>COVER PLATE PARTS</b>                    |   |                        |
| 505   | 1 | Gasket                 |
| 507   | 4 | Screw                  |
| 508   | 1 | Cover Plate            |
| <b>RELIEF VALVE ASSEMBLY GROUP-OPTIONAL</b> |   |                        |
| 901   | 1 | Block                  |
| 902   | 1 | Screw                  |
| 903   | 1 | Relief Valve Cartridge |
| 1219  | 1 | O-Ring (PVWJ-025)      |
| 1222  | 1 | O-Ring (PVWJ-034/-046) |

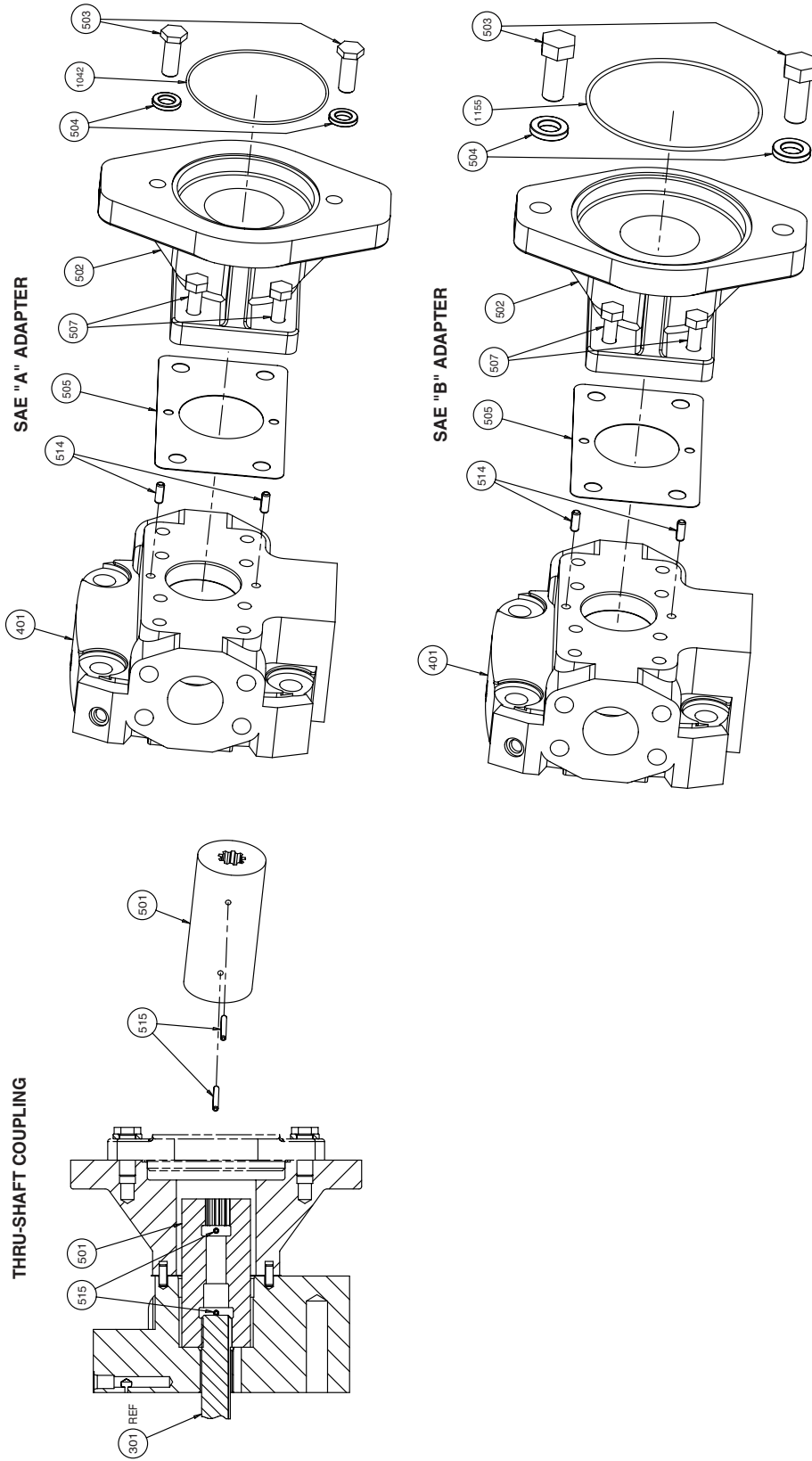

OILG0301

Figure 15. Exploded parts drawing, PVWJ-025/-034/-046 B-Frame, Thru-Shaft Coupling, SAE "A" and SAE "B" Adapter (520024-201 sheet 3 of 4).

| Item                              | Qty. | Description |
|-----------------------------------|------|-------------|
| <b>DRIVE SHAFT ASSEMBLY GROUP</b> |      |             |
| 301                               | 1    | Drive Shaft |
| <b>VALVE PLATE ASSEMBLY GROUP</b> |      |             |
| 401                               | 1    | Valve Plate |

| <b>DUAL PUMP ADAPTER PARTS</b> |   |          |
|--------------------------------|---|----------|
| 501                            | 1 | Coupling |
| 502                            | 1 | Adapter  |
| 503                            | 2 | Screw    |
| 504                            | 2 | Washer   |
| 505                            | 1 | Gasket   |

|      |   |          |
|------|---|----------|
| 507  | 4 | Screw    |
| 514  | 1 | Roll Pin |
| 515  | 1 | Roll Pin |
| 1042 | 1 | O-Ring   |
| 1155 | 1 | O-Ring   |

Document Number: 520024-SK2  
Revision: New

Reference 520024-201  
SERVICE KIT Drawings figures 13-15

**SERVICE KITS**  
PVWJ B-Frame Units (PVWJ-025/-034/-046)

| Description                           | Kit No.    | Design Series | Items Included (quantity is 1 unless noted) |
|---------------------------------------|------------|---------------|---|
| <b>Housing Kits</b>                   |            |               |   |
| All Models                            | K51121-101 | A1            | 001, 005(4), 007, 1010(2), 1237, 1252       |
| <b>Rotating Group Bearing Kit</b>     |            |               |   |
| All Models                            | L51065-1   | A1            | 202, 208                                    |
| <b>Shaft &amp; Bearing Kits</b>       |            |               |   |
| PVWJ-025/-034/-046                    |            |               |   |
| 7/8" Dia. Keyed (Code Y)              | L51129-11  | A1            | 301, 302, 303, 304, 305, 306                |
| 1" Dia. Keyed (Code B)                | L51129-15  | A1            | 301, 302, 303, 304, 305, 306                |
| 7/8" 13T Spline (Code S)              | L51129-13  | A1            | 301, 302, 304, 305, 306                     |
| 1" 15T Spline (Code C)                | L51129-17  | A1            | 301, 302, 304, 305, 306                     |
| 7/8" 13T Spline (Code D) (Industrial) | L51129-39Z | A1            | 301, 302, 304, 305, 306                     |
| 7/8" Dia. Keyed (Code Y)              | L51519-11A | A1            | 301, 302, 303, 304, 305, 306                |
| 1" Dia. Keyed (Code B)                | L51519-11  | A1            | 301, 302, 303, 304, 305, 306                |
| 7/8" 13T Spline (Code S)(SAE)         | L51519-10  | A1            | 301, 302, 304, 305, 306                     |
| 7/8" 13T Spline (Code D) (Industrial) | L51519-12Z | A1            | 301, 302, 304, 305, 306                     |
| <b>Swashblock Kits</b>                |            |               |   |
| LH (CCW) Models                       | L50480-1   | A1            | 201, 721                                    |
| RH (CW) Models                        | L50480-2   | A1            | 201, 721                                    |
| <b>Saddle Bearing Kit</b>             |            |               |   |
| All models                            | L51053-5   | A1            | 204(2)                                      |
| <b>Rotating Group Kits</b>            |            |               |   |
| PVWJ-025                              | L50167-10  | A1            | 101, 102(9), 103, 104, 105                  |
| PVWJ-034                              | L50167-7   | A1            | 101, 102(9), 103, 104, 105                  |
| PVWJ-046                              | L50168-7   | A1            | 101, 102(9), 103, 104, 105                  |

|  |            |    |   |
|--|------------|----|---|
| <b>Saddle Kit</b>                            |            |    |   |
| All models                                   | L51052-7   | A1 | 204(2), 207(2), 209   |
| <b>Valve Plate Kits</b>                      |            |    |   |
| PVWJ-025                                     |            |    |   |
| LH Rear Port (Code "SA")                     | K51102-201 | A1 | 401, 403(4), 601(2), 1010, 1252, 1902(2)                    |
| RH Rear Port (Code "SA")                     | K51102-202 | A1 | 401, 403(4), 601(2), 1010, 1252, 1902(2)                    |
| LH Side Port, Thru-Shaft (Code "DF" & "DR")  | K51102-203 | A1 | 401, 403(4), 601(2), 1010, 1252, 1902(2)                    |
| RH Side Port, Thru-Shaft (Code "DF" & "DR")  | K51102-204 | A1 | 401, 403(4), 601(2), 1010, 1252, 1902(2)                    |
| PVWJ-034                                     |            |    |   |
| LH Rear Port (Code "SA")                     | K51102-205 | A1 | 401, 403(4), 601(2), 1010, 1252, 1902(2)                    |
| RH Rear Port (Code "SA")                     | K51102-206 | A1 | 401, 403(4), 601(2), 1010, 1252, 1902(2)                    |
| LH Side Port, Thru-Shaft (Code "DF" & "DR")  | K51102-207 | A1 | 401, 403(4), 601(2), 1010, 1252, 1902(2)                    |
| RH Side Port, Thru-Shaft (Code "DF" & "DR")  | K51102-208 | A1 | 401, 403(4), 601(2), 1010, 1252, 1902(2)                    |
| PVWJ-046                                     |            |    |   |
| LH Rear Port (Code "SA")                     | K51102-209 | A1 | 401, 403(4), 601(2), 1010, 1252, 1902(2)                    |
| RH Rear Port (Code "SA")                     | K51102-210 | A1 | 401, 403(4), 601(2), 1010, 1252, 1902(2)                    |
| LH Side Port, Thru-Shaft (Code "DF" & "DR")  | K51102-211 | A1 | 401, 403(4), 601(2), 1010, 1252, 1902(2)                    |
| RH Side Port, Thru-Shaft (Code "DF" & "DR")  | K51102-212 | A1 | 401, 403(4), 601(2), 1010, 1252, 1902(2)                    |
| <b>Pump Seal Kit</b>                         |            |    |   |
| All models                                   | K50825-200 | A1 | 007, 1010(2), 1237, 1252, 1902(2)                           |
| <b>Piston &amp; Shoe Kits</b>                |            |    |   |
| PVWJ-025                                     | L51349-900 | A1 | 102(9)  |
| PVWJ-034                                     | L50146-900 | A1 | 102(9)  |
| PVWJ-046                                     | L50175-900 | A1 | 102(9)  |
| <b>Shoe Retainer &amp; Holddown Ball Kit</b> |            |    |   |
| All models                                   | L50132     | A1 | 103, 104  |
| <b>Tag Kit</b>                               |            |    |   |
| All models                                   | L50921     | A1 | 003, 008(2)   |
| <b>Control Pin</b>                           |            |    |   |
| All models                                   | 51339-5    | A1 | 721   |
| <b>Cover Plate Kit</b>                       |            |    |   |
| All models                                   | L50671     | A1 | 505, 507(4), 508  |
| <b>Coupling &amp; Adapter Kits</b>           |            |    |   |
| SAE A Adapter                                | L51081-53  | A1 | 501, 502, 503(2), 504(2), 505, 507(4), 514(2), 515(2), 1042 |
| SAE B Adapter                                | L51081-43  | A1 | 501, 502, 503(2), 504(2), 505, 507(4), 514(2), 515(2), 1155 |





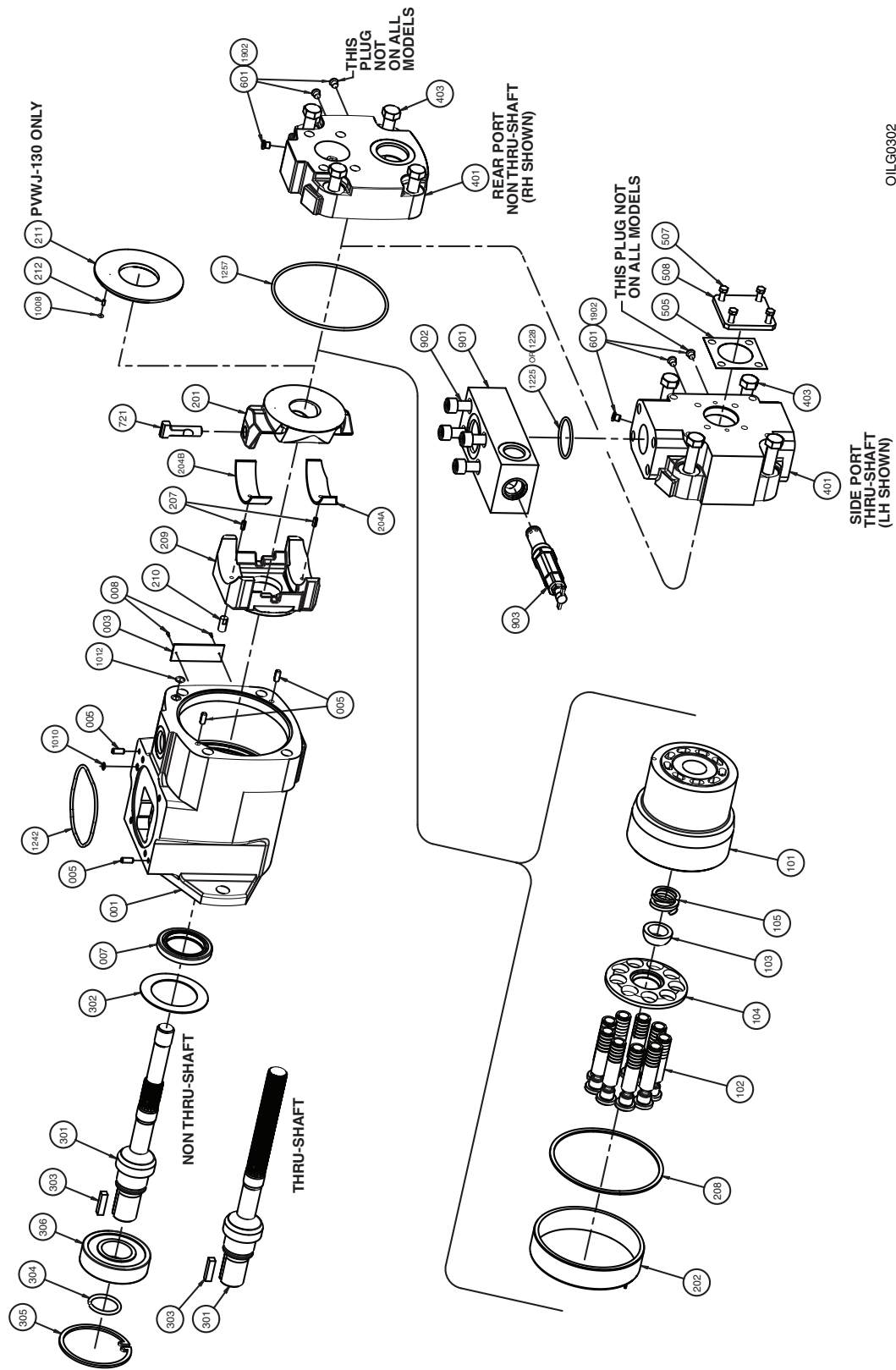

OILG0302

Figure 16. Exploded parts drawing, PVWJ-064/-076/-098/-130 C-Frame (520024-301 sheet 2 of 4).

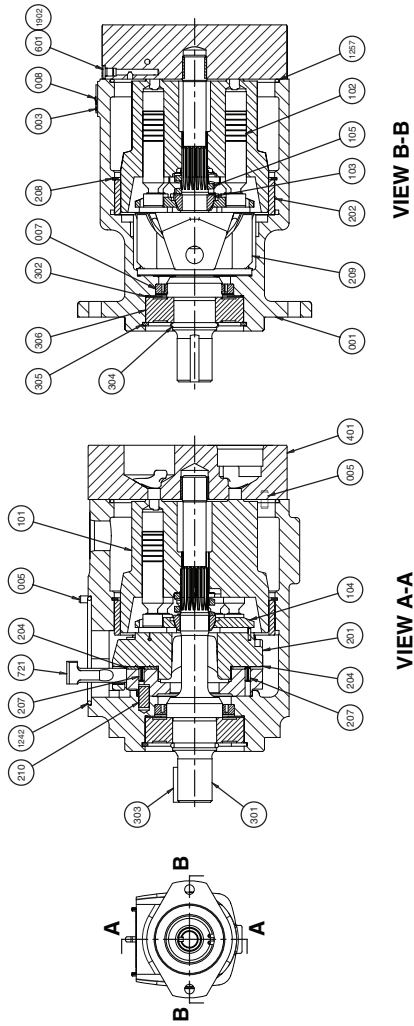

OILG0303

Figure 17. Cross section and plan view parts drawing, -064/-076/-098/-130 C-Frame (520024-301 sheet 1 of 4).

### PVWJ-064-076/-098/-130 C-FRAME PUMP PARTS LIST

| Item                          | Qty. | Description            |
|-------------------------------|------|------------------------|
| <b>HOUSING ASSEMBLY GROUP</b> |      |                        |
| 001                           | 1    | Pump Housing           |
| 003                           | 1    | Name Tag               |
| 005                           | 4    | Roll Pin               |
| 007                           | 1    | Shaft Seal             |
| 008                           | 2    | Drive Screws           |
| 1010                          | 1    | O-Ring                 |
| 1012                          | 1    | O-Ring                 |
| 1242                          | 1    | O-Ring                 |
| 1257                          | 1    | O-Ring                 |
| <b>ROTARY ASSEMBLY GROUP</b>  |      |                        |
| 101                           | 1    | Barrel                 |
| 102                           | 9    | Piston & Shoe Assembly |
| 103                           | 1    | Fulcrum Ball           |
| 104                           | 1    | Shoe Retainer          |
| 105                           | 1    | Shoe Retainer Spring   |

|                                   |        |   |
|-----------------------------------|--------|---|
| <b>SWASHBLOCK ASSEMBLY GROUP</b>  |        |   |
| 201                               | 1      | Swashblock                              |
| 202                               | 1      | Hydrodynamic Bearing                    |
| 204A                              | 1      | Saddle Bearing (PVWJ-064)               |
| 204B                              | 1 or 2 | Saddle Bearing (PVWJ-064/-076/-098)     |
| 204C                              | 2      | Saddle Bearing (PVWJ-130)               |
| 207                               | 2      | Saddle Bearing Locating Pin             |
| 208                               | 1      | Retaining Ring                          |
| 209                               | 1      | Saddle Block                            |
| 210                               | 1      | Saddle Block Locating Ring              |
| 211                               | 1      | Wear Plate (PVWJ-130 only)              |
| 212                               | 1      | Wear Plate Locating Pin (PVWJ-130 only) |
| 721                               | 1      | Control Pin                             |
| 1008                              | 1      | O-Ring (PVWJ-130 only)                  |
| <b>DRIVE SHAFT ASSEMBLY GROUP</b> |        |   |
| 301                               | 1      | Drive Shaft                             |
| 302                               | 1      | Seal Retainer                           |
| 303                               | 1      | Key                                     |
| 304                               | 1      | Shaft Retainer Ring                     |
| 305                               | 1      | Shaft Bearing Retainer Ring             |
| 306                               | 1      | Front Drive Shaft Bearing               |

|   |        |                             |
|---|--------|-----------------------------|
| <b>VALVE PLATE ASSEMBLY GROUP</b>           |        |                             |
| 401   | 1      | Valve Plate                 |
| 403   | 4      | Screw                       |
| 601   | 2 or 3 | Plug                        |
| 1902  | 2 or 3 | O-Ring                      |
| <b>COVER PLATE PARTS</b>                    |        |                             |
| 505   | 1      | Gasket                      |
| 507   | 4      | Screw                       |
| 508   | 1      | Cover Plate                 |
| <b>RELIEF VALVE ASSEMBLY GROUP-OPTIONAL</b> |        |                             |
| 901   | 1      | Block                       |
| 902   | 1      | Screw                       |
| 903   | 1      | Relief Valve Cartridge      |
| 1225  | 1      | O-Ring (PVWJ-064)           |
| 1228  | 1      | O-Ring (PVWJ-076/-098/-130) |

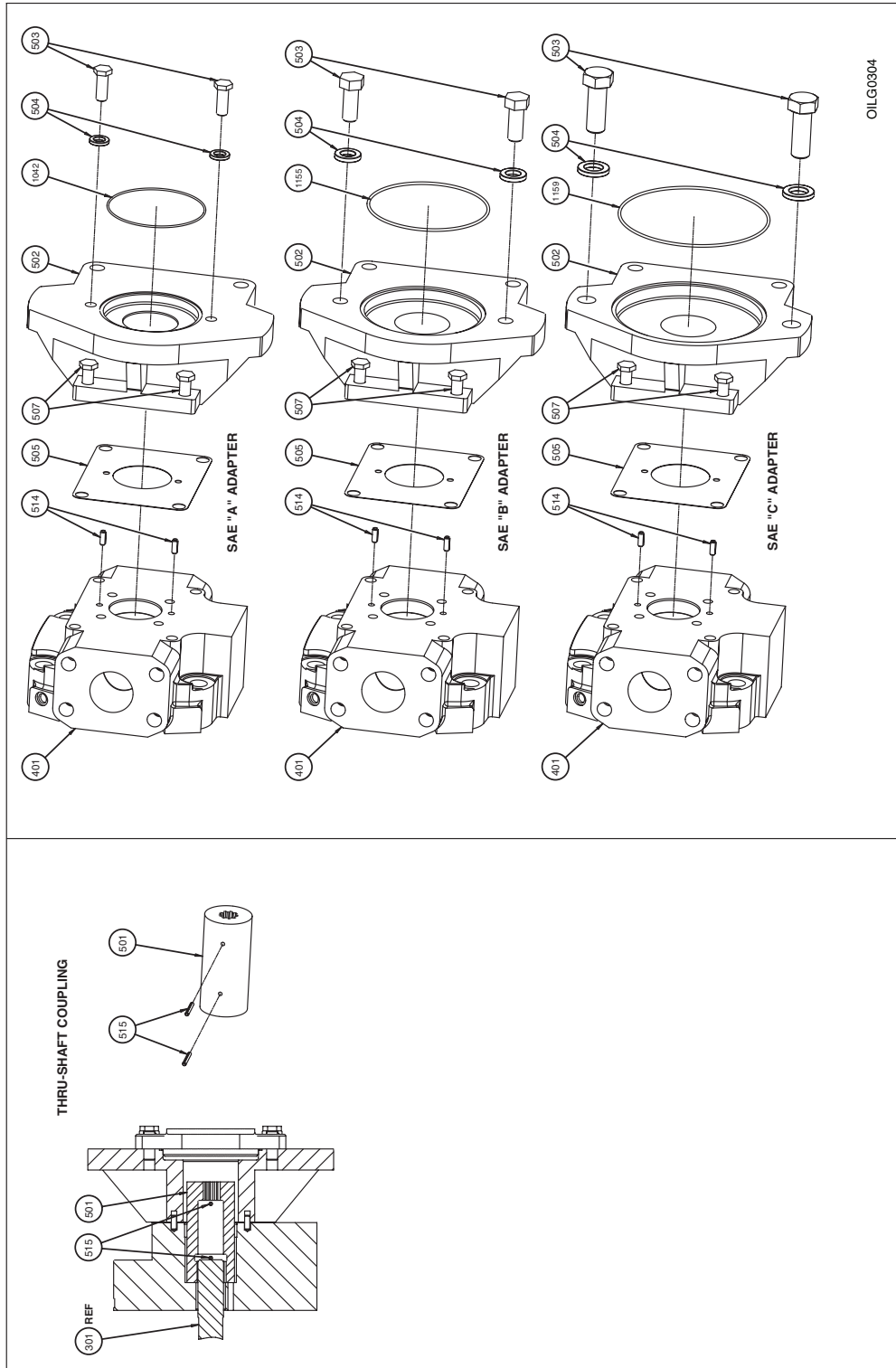

OILG0304

Figure 18. Exploded parts drawing, PVWJ-064/-076/-098/-130 C-Frame, Thru-Shaft Coupling, SAE "A", SAE "B" and SAE "C" Adapter (520024-301 sheet 3 of 4).

| Item                              | Qty. | Description |
|-----------------------------------|------|-------------|
| <b>DRIVE SHAFT ASSEMBLY GROUP</b> |      |             |
| 301                               | 1    | Drive Shaft |
| <b>VALVE PLATE ASSEMBLY GROUP</b> |      |             |
| 401                               | 1    | Valve Plate |

| <b>DUAL PUMP ADAPTER</b> |   |          |
|--------------------------|---|----------|
| 501                      | 1 | Coupling |
| 502                      | 1 | Adapter  |
| 503                      | 2 | Screw    |
| 504                      | 2 | Washer   |
| 505                      | 1 | Gasket   |

|      |   |          |
|------|---|----------|
| 507  | 4 | Screw    |
| 514  | 2 | Roll Pin |
| 515  | 2 | Roll Pin |
| 1042 | 1 | O-Ring   |
| 1155 | 1 | O-Ring   |
| 1159 | 1 | O-Ring   |

Document Number: 520024-SK3  
Revision: New

Reference 520024-301  
SERVICE KIT Drawings figures 16-18

**SERVICE KITS**  
PVWJ C-Frame Units  
(PVWJ-064/-076/-098/-130)

| Description                                      | Kit No.    | Design Series | Items Included (quantity is 1 unless noted) |
|--|------------|---------------|---|
| <b>Housing Kits</b>                              |            |               |   |
| All Models                                       | K51114-101 | A1            | 001, 005(4), 007, 1010(2), 1242, 1257       |
| <b>Rotating Group Bearing Kit</b>                |            |               |   |
| All Models                                       | L51066-1   | A1            | 202, 208                                    |
| <b>Shaft &amp; Bearing Kits</b>                  |            |               |   |
| 1 1/4" Dia. Keyed (Code Y) Standard              | L51130-11  | A1            | 301, 302, 303, 304, 305, 306                |
| 1 1/4" 14T Spline (Code S) Standard (SAE)        | L51130-13  | A1            | 301, 302, 304, 305, 306                     |
| 1 1/4" 14T Spline (Code D) Standard (Industrial) | L51130-13Z | A1            | 301, 302, 304, 305, 306                     |
| 1 1/4" Dia. Keyed (Code Y) T-S                   | L51520-11  | A1            | 301, 302, 303, 304, 305, 306                |
| 1 1/4" 14T Spline (Code S) T-S (SAE)             | L51520-10  | A1            | 301, 302, 304, 305, 306                     |
| 1 1/4" 14T Spline (Code D) T-S (Industrial)      | L51520-12Z | A1            | 301, 302, 304, 305, 306                     |
| <b>Swashblock Kits</b>                           |            |               |   |
| PVWJ-064/-076/-098 LH (CCW) Models               | L50481-3   | A1            | 201, 721                                    |
| PVWJ-064/-076/-098 RH (CW) Models                | L50481-5   | A1            | 201, 721                                    |
| PVWJ-130 LH (CCW) Models                         | L50481-4   | A1            | 201, 211, 212, 213, 721                     |
| PVWJ-130 RH (CW) Models                          | L50481-6   | A1            | 201, 211, 212, 213, 721                     |
| <b>Saddle Bearing Kits</b>                       |            |               |   |
| PVWJ-064   | L51053-8   | A1            | 204A, 204B                                  |
| PVWJ-076 & -098                                  | L51053-6   | A1            | 204B(2)                                     |
| PVWJ-130   | L51053-7   | A1            | 204C(2)                                     |
| <b>Rotating Group Kits</b>                       |            |               |   |
| PVWJ-064   | L50108-11  | A1            | 101, 102(9), 103, 104, 105                  |
| PVWJ-076   | L50087-7   | A1            | 101, 102(9), 103, 104, 105                  |
| PVWJ-098   | L50108-7   | A1            | 101, 102(9), 103, 104, 105                  |
| PVWJ-130   | L50108-8   | A1            | 101, 102(9), 103, 104, 105                  |
| <b>Saddle Kits</b>                               |            |               |   |
| PVWJ-064   | L51052-13  | A1            | 204A, 204B, 207(2), 209                     |
| PVWJ-076 & -098                                  | L51052-8   | A1            | 204B(2), 207(2), 209                        |
| PVWJ-130   | L51052-9   | A1            | 204C(2), 207(2), 209                        |

| Valve Plate Kits                              |            |    |  |
|---|------------|----|--|
| <b>PVWJ-064</b>                               |            |    |  |
| LH Rear Port (Code "SA")                      | K51103-213 | A1 | 401, 403(4), 405(2), 408(2), 1012, 1257    |
| RH Rear Port (Code "SA")                      | K51103-214 | A1 | 401, 403(4), 405(3), 408(3), 1012, 1257    |
| LH Side Port, Thru Shaft (Code "DF" & "DR")   | K51103-215 | A1 | 401, 403(4), 405(2), 408(2), 1012, 1257    |
| RH Side Port, Thru Shaft (Code "DF" & "DR")   | K51103-216 | A1 | 401, 403(4), 405(3), 408(3), 1012, 1257    |
| <b>PVWJ-076</b>                               |            |    |  |
| LH Rear Port (Code "SA")                      | K51103-201 | A1 | 401, 403(4), 405(2), 408(2), 1012, 1257    |
| RH Rear Port (Code "SA")                      | K51103-202 | A1 | 401, 403(4), 405(3), 408(3), 1012, 1257    |
| LH Side Port, Thru Shaft (Code "DF" & "DR")   | K51103-207 | A1 | 401, 403(4), 405(2), 408(2), 1012, 1257    |
| RH Side Port, Thru Shaft (Code "DF" & "DR")   | K51103-208 | A1 | 401, 403(4), 405(3), 408(3), 1012, 1257    |
| <b>PVWJ-098</b>                               |            |    |  |
| LH Rear Port (Code "SA")                      | K51103-203 | A1 | 401, 403(4), 405(2), 408(2), 1012, 1257    |
| RH Rear Port (Code "SA")                      | K51103-204 | A1 | 401, 403(4), 405(3), 408(3), 1012, 1257    |
| LH Side Port, Thru Shaft (Code "DF" & "DR")   | K51103-209 | A1 | 401, 403(4), 405(2), 408(2), 1012, 1257    |
| RH Side Port, Thru Shaft (Code "DF" & "DR")   | K51103-210 | A1 | 401, 403(4), 405(3), 408(3), 1012, 1257    |
| <b>PVWJ-130</b>                               |            |    |  |
| LH Rear Port (Code "SA")                      | K51103-205 | A1 | 401, 403(4), 405(2), 408(2), 1012, 1257    |
| RH Rear Port (Code "SA")                      | K51103-206 | A1 | 401, 403(4), 405(3), 408(3), 1012, 1257    |
| LH Side Port, Thru Shaft (Code "DF" & "DR")   | K51103-211 | A1 | 401, 403(4), 405(2), 408(2), 1012, 1257    |
| RH Side Port, Thru Shaft (Code "DF" & "DR")   | K51103-212 | A1 | 401, 403(4), 405(3), 408(3), 1012, 1257    |
| <b>Pump Seal Kit</b>                          |            |    |  |
| All models                                    | K50826-200 | A1 | 007, 1008, 1010, 1012, 1242, 1257, 1902(3) |
| <b>Piston &amp; Shoe Kits</b>                 |            |    |  |
| PVWJ-064                                      | L51109-900 | A1 | 102(9)                                     |
| PVWJ-076                                      | L51107-900 | A1 | 102(9)                                     |
| PVWJ-098                                      | L51109-901 | A1 | 102(9)                                     |
| PVWJ-130                                      | L51303-900 | A1 | 102(9)                                     |
| <b>Shoe Retainer &amp; Holddown Ball Kits</b> |            |    |  |
| PVWJ-064/-076/-098                            | L50071     | A1 | 103, 104                                   |
| PVWJ-130                                      | L51305-2   | A1 | 103, 104                                   |
| <b>Tag Kit</b>                                |            |    |  |
| All models                                    | L50921     | A1 | 003, 008(2)                                |
| <b>Control Pin</b>                            |            |    |  |
| All models                                    | 51339-2    | A1 | 721  |

|                                    |           |    |   |  |
|------------------------------------|-----------|----|---|--|
| <b>Cover Plate Kit</b>             |           |    |   |  |
| All models                         | L50671    | A1 | 505, 507(4), 508  |  |
| <b>Coupling &amp; Adapter Kits</b> |           |    |   |  |
| SAE A Adapter                      | L51081-52 | A1 | 501, 502, 503(2), 504(2), 505, 507(4), 514(2), 515(2), 1042 |  |
| SAE B Adapter                      | L51081-51 | A1 | 501, 502, 503(2), 504(2), 505, 507(4), 514(2), 515(2), 1155 |  |
| SAE C Adapter                      | L51081-49 | A1 | 501, 502, 503(2), 504(2), 505, 507(4), 514(2), 1159         |  |



---

## **AFTER SALES SERVICES**

At Oilgear we build products to last. It is the nature of this type of machinery to require proper maintenance regardless of the care we put into manufacturing. Oilgear has several service programs in place to help you.

### **STAY-ON-STREAM SERVICE**

By signing up for Oilgear's Stay-On-Stream program, you can prepare for problems before they happen. Certain field tests such as fluid testing, slip testing and electronic profile recording comparisons can be performed by our field service people or your own factory trained personnel. These tests can indicate problems before they become "down-time" difficulties.

## **SERVICE SCHOOLS**

Oilgear conducts training to train your maintenance personnel. "General" hydraulic or electronic training is conducted at our Milwaukee, Wisconsin plant on a regular basis. "Custom" training, specifically addressing your particular hydraulic and electro-hydraulic equipment, can be conducted at your facilities.

### **SPARE PARTS AVAILABILITY**

Prepare for your future needs by stocking Oilgear original factory parts. Having the correct parts and necessary skills "in-plant" enables you to minimize "down-time." Oilgear has developed parts kits to cover likely future needs. Oilgear Field Service Technicians are also ready to assist you and your maintenance people in troubleshooting and repairing equipment.



### **THE OILGEAR COMPANY**

2300 South 51st Street  
Milwaukee, Wisconsin 53219  
phone: 414/327-1700 fax: 414/327-0532  
[www.oilgear.com](http://www.oilgear.com)